

OH44E Unipolar Hall Effect Switch IC

General Description:

Part No.: OH44E Operate temperature: -40~125°C Package:1000pcs/Bag

OH44E unipolar hall IC includes an on-chip Hall voltage generator for magnetic sensing, an amplifier that amplifies the Hall voltage, a schmitt trigger to provide switching hysteresis for noise rejection, and an open-collector output. It detects the changes of Magnetic field and output a digital voltage signal. With the typical feature of wide range of working Voltage, operate temperature and high load capacity, OH44E performs well in many application, such as position control, speed detection and flow detection as a non-contact magnetic sensor.



Features

- High load capacity
- The good consistency
- a wide range of power supply voltage
- high reliability

Applications

- The brushless DC motor, DC fans, DC water pump
- The home appliance control panel sewing equipment, textile machinery
- speed sensor, position detecting, counting and
- The flow sensor, flow meter
- The auto ignition, safety alarm device
- other industrial control field

Absolute Maximum Ratings (T_A=25°C)

Supply Voltage V_{CC}.....4-30V

Output Current I_O.....50mA

Operating Temperature Range T_A-40~150°C

Storage Temperature Range T_S-65~150°C

Magnetic-electrical Transfer Characteristics Functional Block Diagram:

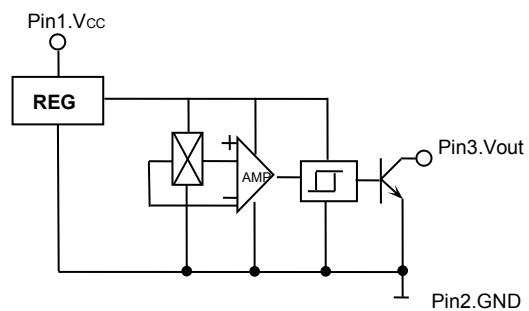
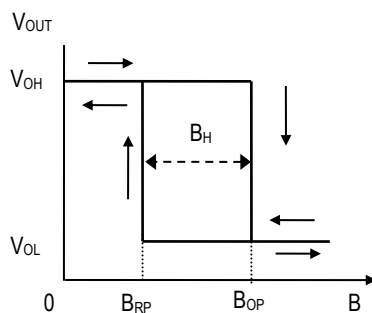

Typical Working Mode

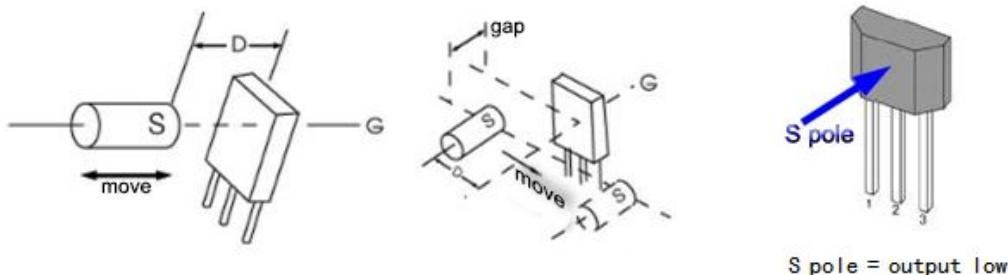

Electrical Characteristics (Ta= 25°C)

Parameter	Symbol	Conditions	Value			Unit
			Min	Typ	Max	
Supply Voltage	V _{CC}		4	-	30	V
Output Saturation Voltage	V _{OL}	V _{CC} =4.5V, I _{out} =20mA, B≥B _{OP}	-	200	400	mV
Output Leakage Current	I _{OH}	V _{out} =24V, B≤B _{RP}	-	1.0	10	μA
Supply Current	I _{CC}	V _{CC} =V _{CCmax} OC output	-	5	-	mA
Output Rise Time	t _r	V _{CC} =12V, R _L =820Ω, C _L =20pF	-	0.5	-	μS
Output Falling Time	t _f		-	0.5	-	μS

Magnetic Characteristics (Ta= 25°C) (1mT = 10 Gauss)

Parameter	symbol	Value			Unit
		Min	Typ	Max	
Operate Point	B _{OP}	-	-	20	mT
Release Point	B _{RP}	3	-	-	mT
Hysteresis	B _H	5	-	7	mT

Dimension (unit:mm)

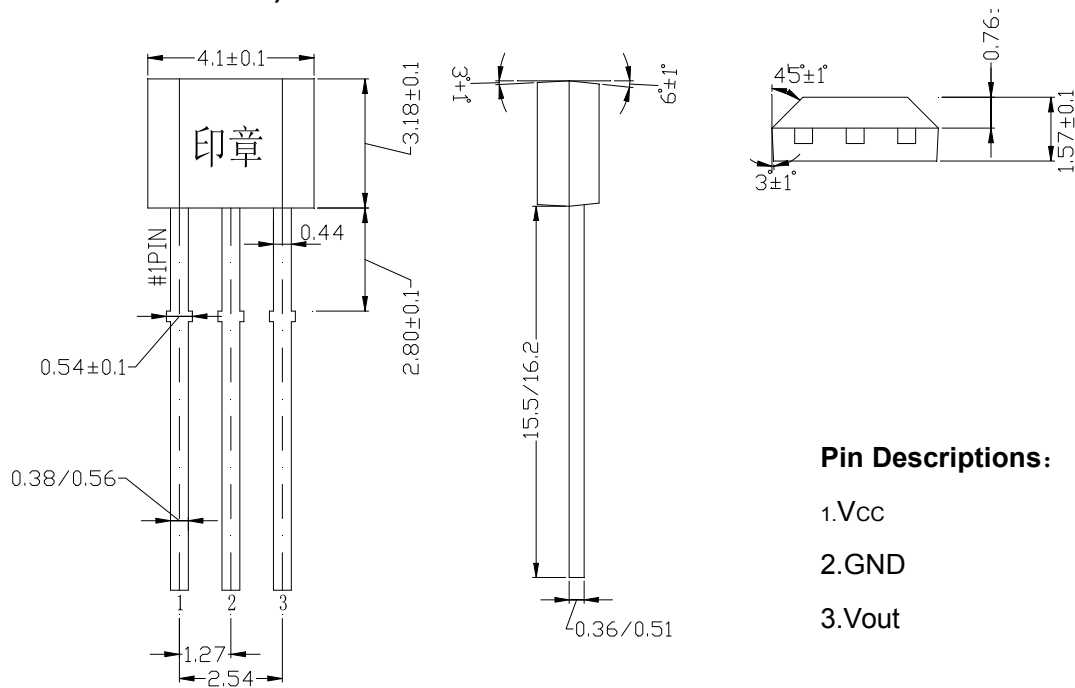

Pin Descriptions:

- 1.V_{CC}
- 2.GND
- 3.V_{out}



Typical Application Cuicuits

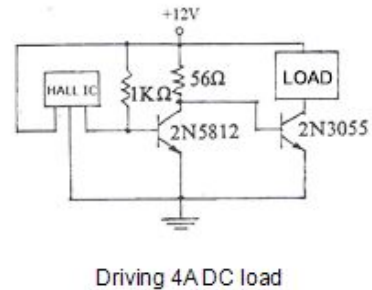
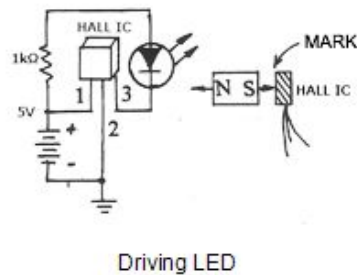
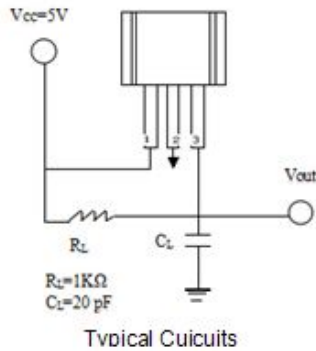

Precautions OH Series Hall ICS

Hall ICs are sensitive devices which performance could be influenced in some extent by magnetic , optical , thermal and mechanical stress.

- 1) A pull-up resistor R_L should be connected between the power supply (Vcc) and the output (Vout) Since most of hall ICs are open collector output (OC output) circuits. Such as OH44E, OH137, OH513, OH543. Hall ICs with Build-in Resistor are not necessary to add one, for example OH921.
- 2) Avoid reversing the power supply (Vcc) and the output (Vout) and overload use. Be careful of the burn and damage caused by instant large current and instantaneous high voltage.
- 3) The Protection circuit should be added in the test cuicuits of hall ICS, such as large capacitor and a voltage stabilizing diode, which could absorb the effects of the external circuit and power fluctuation.
- 4) Try to minimise the mechanical stress applied to the device and leads during the installation, especially on the pins where close to the root of the device when bending shaping etc.
- 5) Strictly regulate the welding temperature and time (lead-free welding process reference). When manual welding, the temperature of soldering iron shall not exceed 260 degrees and time should be less than 3seconds..
- 6) When designing, please fully consider the influence factors of temperature, magnetic field attenuation, the movement way, etc.

