



## UT4812

Power MOSFET

### DUAL N-CHANNEL ENHANCEMENT MODE

#### DESCRIPTION

The **UT4812** can provide excellent  $R_{DS(ON)}$  and low gate charge by using advanced trench technology. The **UT4812** is suitable for using as a load switch or in PWM applications.

#### FEATURES

- \* 30V/6.9A
- \* Low  $R_{DS(ON)}$
- \* Reliable and Rugged

#### SYMBOL

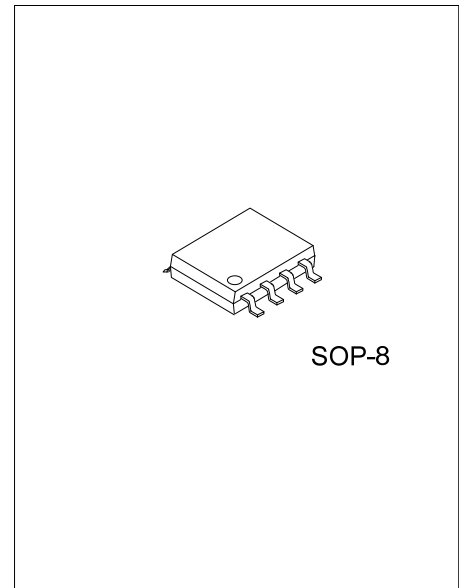
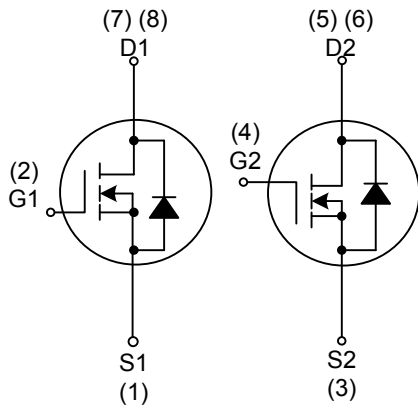

SOP-8

Lead-free: UT4812L  
Halogen-free: UT4812G

#### ORDERING INFORMATION

	Ordering Number			Package	Packing
	Normal	Lead Free Plating	Halogen-Free		
UT4812-S08-R	UT4812L-S08-R	UT4812G-S08-R	SOP-8	Tape Reel	
UT4812-S08-T	UT4812L-S08-T	UT4812G-S08-T	SOP-8	Tube	

<p>UT4812L-S08-R</p> <p>(1) Packing Type</p> <p>(2) Package Type</p> <p>(3) Lead Plating</p>	<p>(1) R: Tape Reel, T: Tube</p> <p>(2) S08: SOP-8</p> <p>(3) G: Halogen Free, L: Lead Free Plating, Blank: Pb/Sn</p>
--	---

■ PIN CONFIGURATION

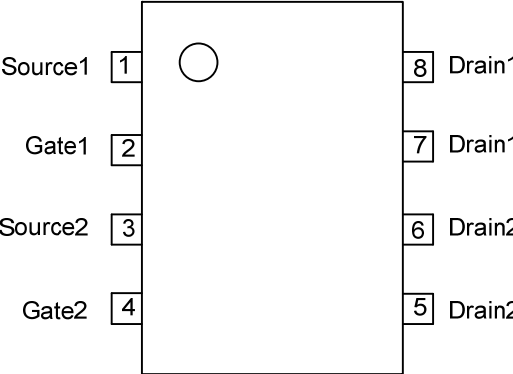

■ ABSOLUTE MAXIMUM RATINGS ( $T_A = 25^\circ\text{C}$ , unless otherwise specified)

PARAMETER	SYMBOL	RATINGS	UNIT
Drain-Source Voltage	$V_{DSS}$	30	V
Gate-Source Voltage	$V_{GSS}$	$\pm 20$	
Continuous Drain Current (Note3)	$I_D$	6.9	A
Pulsed Drain Current (Note1)	$I_{DM}$	30	
Power Dissipation	$P_D$	2	W
Junction Temperature	$T_J$	+150	$^\circ\text{C}$
Storage Temperature	$T_{STG}$	-55 ~ +150	$^\circ\text{C}$

Note: Absolute maximum ratings are those values beyond which the device could be permanently damaged. Absolute maximum ratings are stress ratings only and functional device operation is not implied.

■ THERMAL DATA

PARAMETER	SYMBOL	MIN	TYP	MAX	UNIT
Junction-to-Ambient	$\theta_{JA}$		74	110	$^\circ\text{C/W}$

■ ELECTRICAL CHARACTERISTICS ( $T_J = 25^\circ\text{C}$ , unless otherwise specified)

PARAMETER	SYMBOL	TEST CONDITIONS	MIN	TYP	MAX	UNIT
<b>OFF CHARACTERISTICS</b>						
Drain-Source Breakdown Voltage	$BV_{DSS}$	$V_{GS} = 0\text{ V}, I_D = 250\mu\text{A}$	30			V
Drain-Source Leakage Current	$I_{DSS}$	$V_{DS} = 30\text{V}, V_{GS} = 0\text{ V}$			1	$\mu\text{A}$
Gate-Source Leakage Current	$I_{GSS}$	$V_{DS} = 0\text{ V}, V_{GS} = \pm 20\text{V}$			100	nA
<b>ON CHARACTERISTICS</b>						
Gate Threshold Voltage	$V_{GS(TH)}$	$V_{DS} = V_{GS}, I_D = 250\mu\text{A}$	1	1.9	3	V
Drain-Source On-State Resistance (Note2)	$R_{DS(ON)}$	$V_{GS} = 10\text{V}, I_D = 6.9\text{A}$		22.5	28	m $\Omega$
		$V_{GS} = 4.5\text{V}, I_D = 5.0\text{A}$		34.5	42	m $\Omega$
<b>DYNAMIC PARAMETERS</b>						
Input Capacitance	$C_{ISS}$	$V_{DS} = 15\text{ V}, V_{GS} = 0\text{V}, f = 1\text{MHz}$		680	820	pF
Output Capacitance	$C_{OSS}$		102			
Reverse Transfer Capacitance	$C_{RSS}$		77	108		
<b>SWITCHING PARAMETERS</b>						
Turn-ON Delay Time	$t_{D(ON)}$	$V_{GS} = 10\text{V}, V_{DS} = 15\text{V}, R_L = 2.2\Omega, R_{GEN} = 3\Omega$		4.6	7	ns
Turn-ON Rise Time	$t_R$		4.1	6.2		
Turn-OFF Delay Time	$t_{D(OFF)}$		20.6	30		
Turn-OFF Fall-Time	$t_F$		5.2	7.5		
Total Gate Charge	$Q_G$	$V_{DS} = 15\text{V}, V_{GS} = 10\text{V}, I_D = 6.9\text{A}$		13.84	17	nC
Gate Source Charge	$Q_{GS}$		1.82			
Gate Drain Charge	$Q_{GD}$		3.2			
<b>SOURCE-DRAIN DIODE RATINGS AND CHARACTERISTICS</b>						
Drain-Source Diode Forward Voltage(Note2)	$V_{SD}$	$I_S = 1\text{A}$		0.76	1	V
Maximum Continuous Drain-Source Diode Forward Current	$I_S$				3	A
Body Diode Reverse Recovery Time	$t_{RR}$	$I_F = 6.9\text{ A}, dI/dt = 100\text{A}/\mu\text{s}$		16.5	20	ns
Body Diode Reverse Recovery Charge	$Q_{RR}$	$I_F = 6.9\text{ A}, dI/dt = 100\text{A}/\mu\text{s}$		7.8	10	nC

- Notes: 1. Pulse width limited by  $T_{J(MAX)}$   
 2. Pulse width  $\leq 300\mu\text{s}$ , duty cycle  $\leq 2\%$ .  
 3. Surface Mounted on  $1\text{in}^2$  pad area,  $t \leq 10\text{sec}$ .

## TYPICAL CHARACTERISTICS

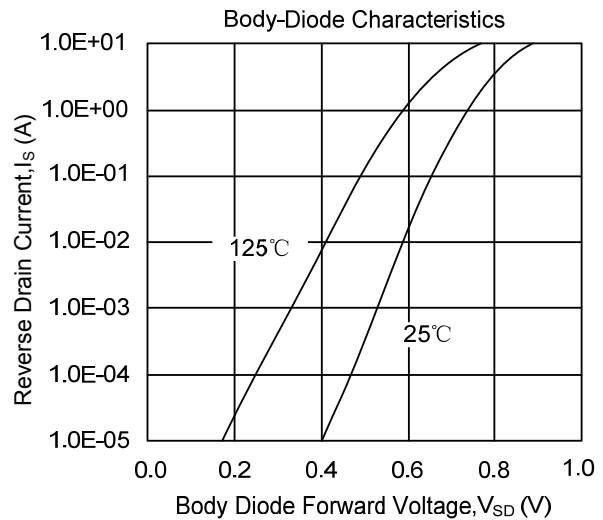
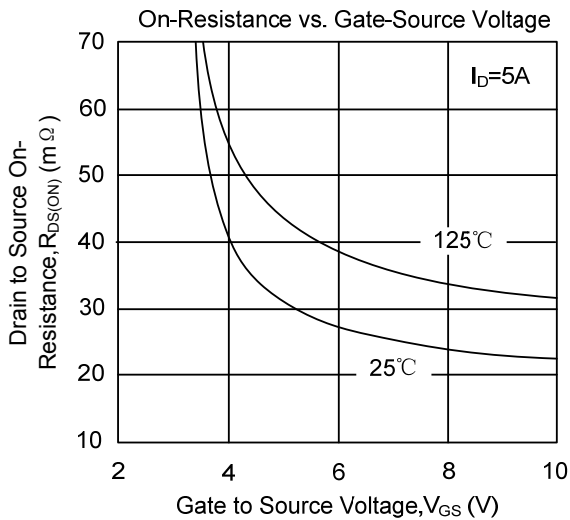
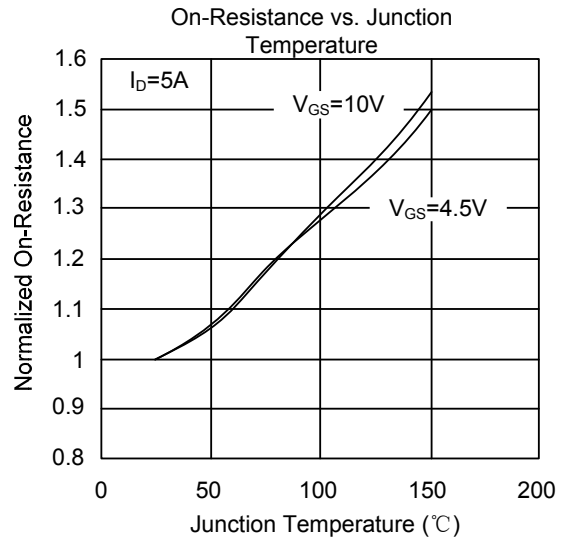
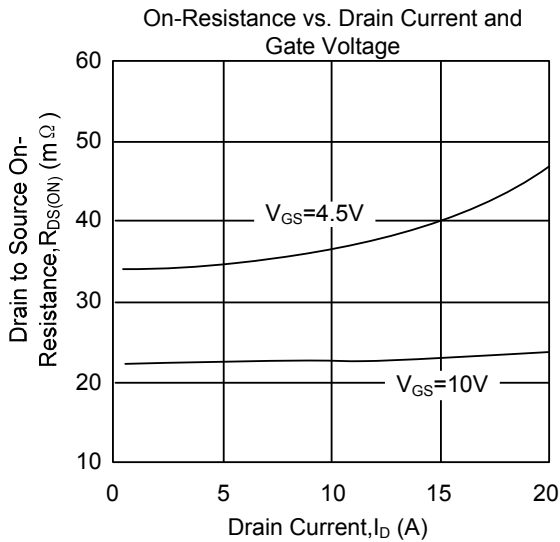
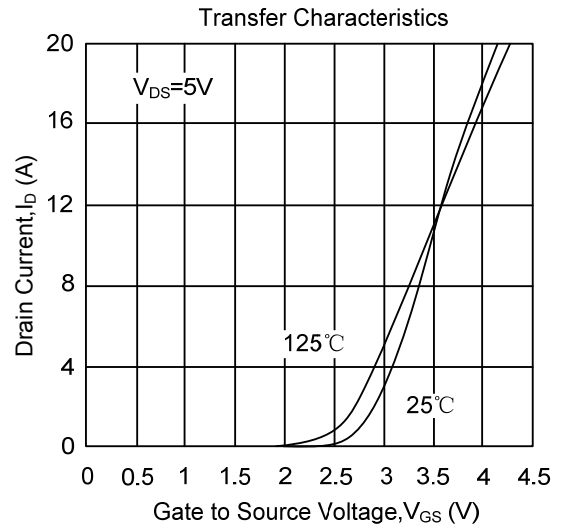
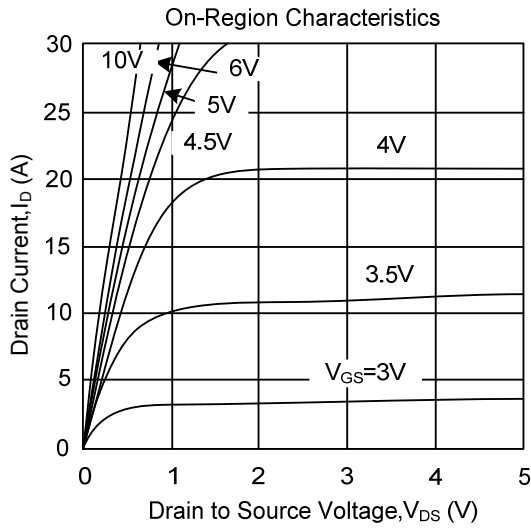

## TYPICAL CHARACTERISTICS(Cont.)

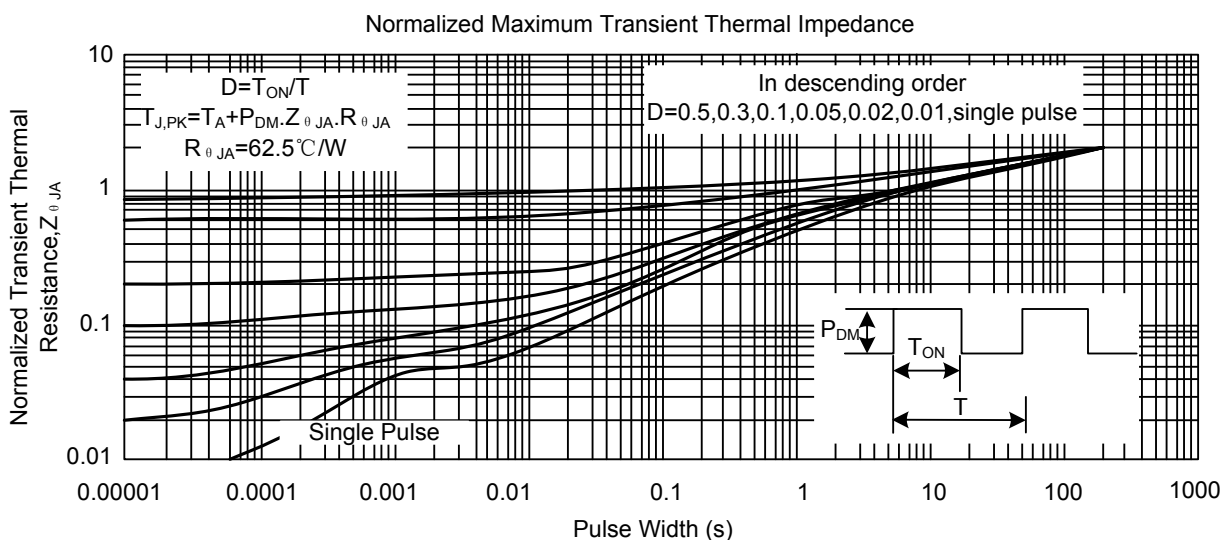
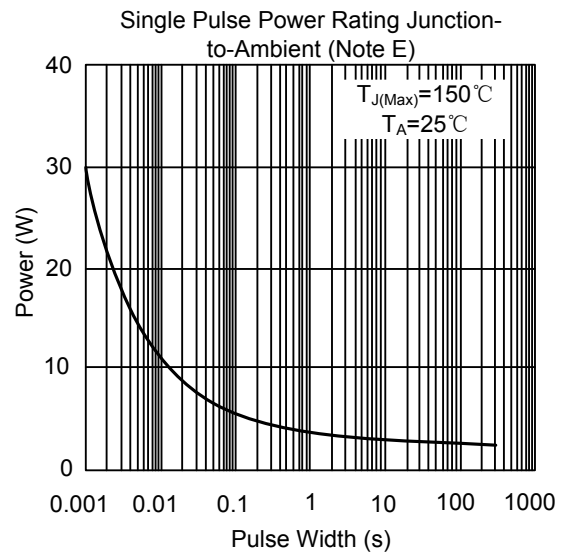
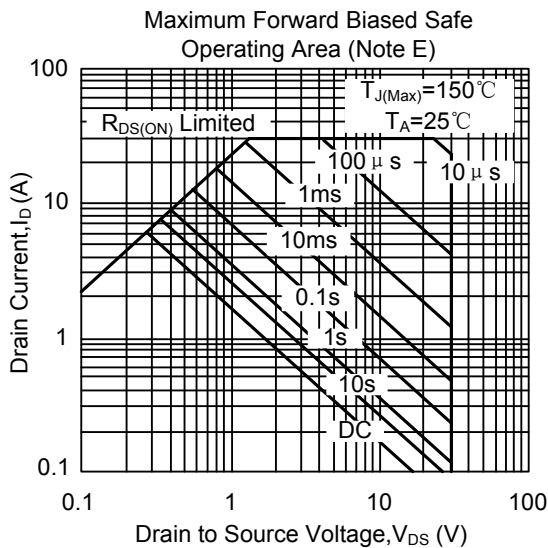
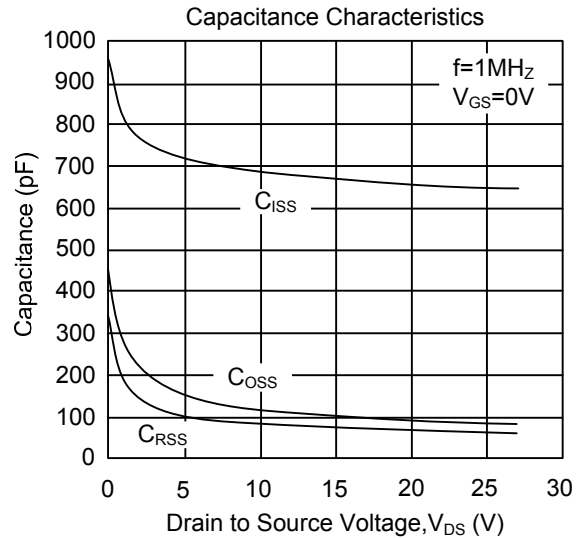
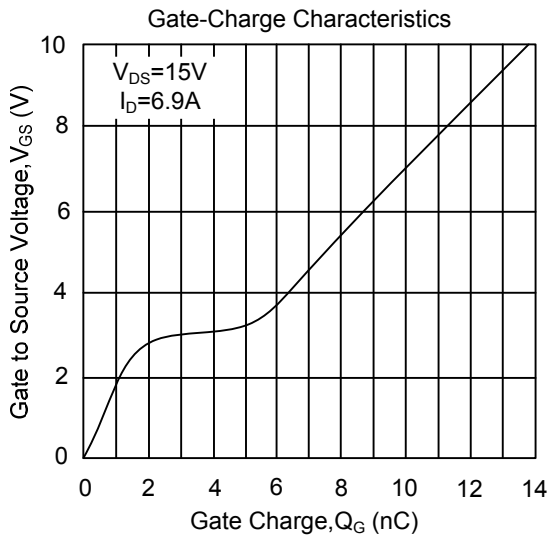

UTC assumes no responsibility for equipment failures that result from using products at values that exceed, even momentarily, rated values (such as maximum ratings, operating condition ranges, or other parameters) listed in products specifications of any and all UTC products described or contained herein. UTC products are not designed for use in life support appliances, devices or systems where malfunction of these products can be reasonably expected to result in personal injury. Reproduction in whole or in part is prohibited without the prior written consent of the copyright owner. The information presented in this document does not form part of any quotation or contract, is believed to be accurate and reliable and may be changed without notice.