



M3368

Preliminary

LINEAR INTEGRATED CIRCUIT

3-INPUT VIDEO SWITCH WITH 6dB AMPLIFIER

DESCRIPTION

The UTC **M3368** is three input integrated video switch with selects one video or audio signal from three input signals.

It contains 6dB amplifier and its operating supply voltage range is 4.75 to 13V and bandwidth is 5MHz.

Crosstalk is 65dB (at 4.43MHz).

FEATURES

- * Operating Voltage: 4.75 ~ 13V
- * 3 Input-1 Output
- * Internal 6dB Amplifier
- * Muting Function available
- * Internal Clamp Function
- * Cross-talk 65dB (at 4.43MHz)
- * Wide Frequency Range 5MHz (1Vp-p Input)

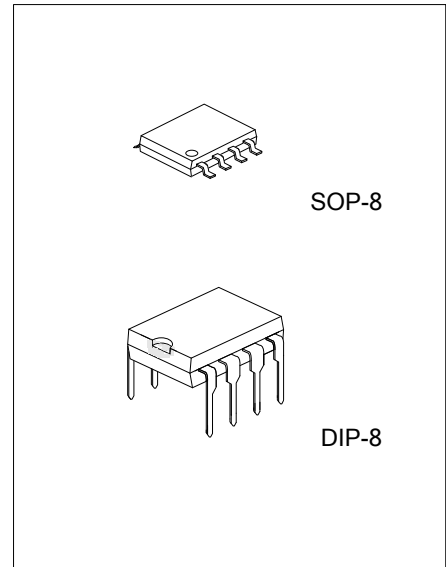

ORDERING INFORMATION

Ordering Number		Package	Packing
Lead Free	Halogen Free		
M3368L-S08-R	M3368G-S08-R	SOP-8	Tape Reel
M3368L-S08-T	M3368G-S08-T	SOP-8	Tube
M3368L-D08-T	M3368G-D08-T	DIP-8	Tube

<p>M3368L-S08-R</p> <p>(1) Packing Type</p> <p>(2) Package Type</p> <p>(3) Lead Free</p>	<p>(1) R: Tape Reel, T: Tube</p> <p>(2) S08: SOP-8, D08: DIP-8</p> <p>(3) G: Halogen Free, L: Lead Free</p>
--	---

■ PIN CONFIGURATION

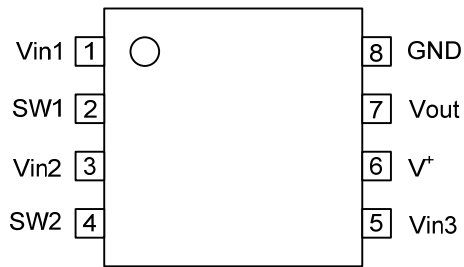

■ BLOCK DIAGRAM

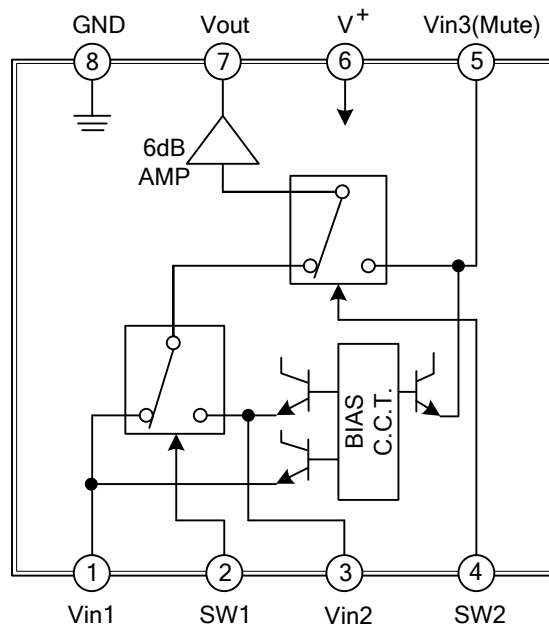

■ PIN DESCRIPTION

PIN NO.	PIN NAME	INSIDE EQUIVALENT CIRCUIT	PIN NO.	PIN NAME	INSIDE EQUIVALENT CIRCUIT
1	VIN1		5	VIN3 (Mute)	
2	SW1		6	V+	
3	VIN2		7	VOUT	
4	SW2		8	GND	

■ INPUT CONTROL SIGNAL-OUTPUT SIGNAL

SW1	SW2	OUTPUT SIGNAL
L	L	Vin 1
H	L	Vin 2
L/H	H	Vin 3

Note: Input clamp voltage is about 2/5 of supply voltage

■ ABSOLUTE MAXIMUM RATING ($T_A=25^\circ\text{C}$)

PARAMETER	SYMBOL	RATINGS	UNIT
Supply Voltage	V^+	15	V
Power Dissipation	DIP-8	500	mW
	SOP-8	300	
Operating Temperature	T_{OPR}	-40~+85	$^\circ\text{C}$
Storage Temperature	T_{STG}	-40~+125	$^\circ\text{C}$

Note: Absolute maximum ratings are those values beyond which the device could be permanently damaged. Absolute maximum ratings are stress ratings only and functional device operation is not implied.

■ ELECTRICAL CHARACTERISTICS ($V^+=5\text{V}, T_A=25^\circ\text{C}$)

PARAMETER	SYMBOL	TEST CONDITIONS	MIN	TYP	MAX	UNIT
Recommended Supply Voltage	V^+		4.75		13.0	V
Operating Current	I_{CC}	S1=S2=S3=S4=S5=2	9.5	14.0	21.0	mA
Voltage Gain	G_V	$V_{in}=1.0\text{Vp-p}$, 1MHz, V_o/V_i , $R_L=1\text{k}\Omega$	5.5	6.0	6.5	dB
Frequency Characteristic	G_f	$V_{in}=1.0\text{Vp-p}$, $V_o(10\text{MHz})/V_o(1\text{MHz})$, $R_L=1\text{k}\Omega$	-1.0		+1.0	dB
Differential Gain	DG	$V_{in}=1.0\text{Vp-p}$, staircase, $R_L=1\text{k}\Omega$		0.3		%
Differential Phase	DP	$V_{in}=1.0\text{Vp-p}$, staircase, $R_L=1\text{k}\Omega$		0.3		deg.
Output Offset Voltage	V_{off}	S1=S2=S3=2, S5=1→2, V_o : voltage change			±60	mV
Crosstalk	CT	$V_{in}=1\text{Vp-p}$, 4.43MHz, V_o/V_i		-65		dB
Switch Change Voltage	V_{CH}	All inside SW: ON	2.4			V
	V_{CL}	All inside SW: OFF			0.8	

Note: Unless specified, tested with three mode below.

(a) S1=1, S2=S3=S4=S5=2 (b) S2=S4=1, S1=S3=S5=2 (c) S1=S2=2, S3=S5=1, S4=1 or 2

■ APPLICATION

Oscillation Prevention on light loading conditions Recommended under circuit.

This IC requires $1M\Omega$ resistance between INPUT and GND pin for clamp type input since the minute current causes an unstable pin voltage.

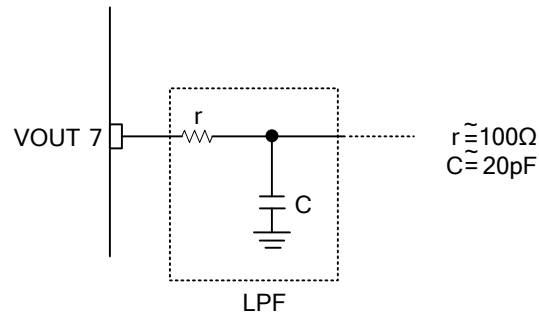

This IC requires $1M\Omega$ resistance between INPUT and GND pin for clamp type input since the minute current causes an unstable pin voltage.

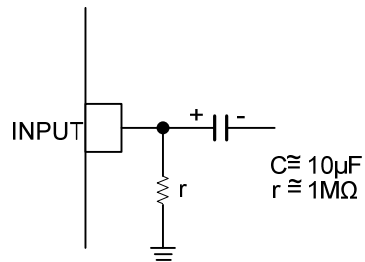

This IC requires $0.1\mu F$ capacitor between INPUT and GND, $1M\Omega$ resistance between INPUT and GND for clamp type input at mute mode.

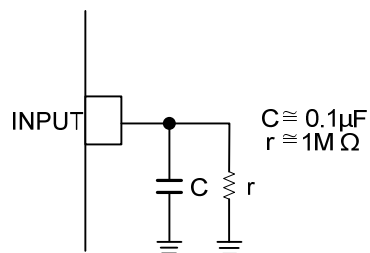

■ TEST CIRCUIT

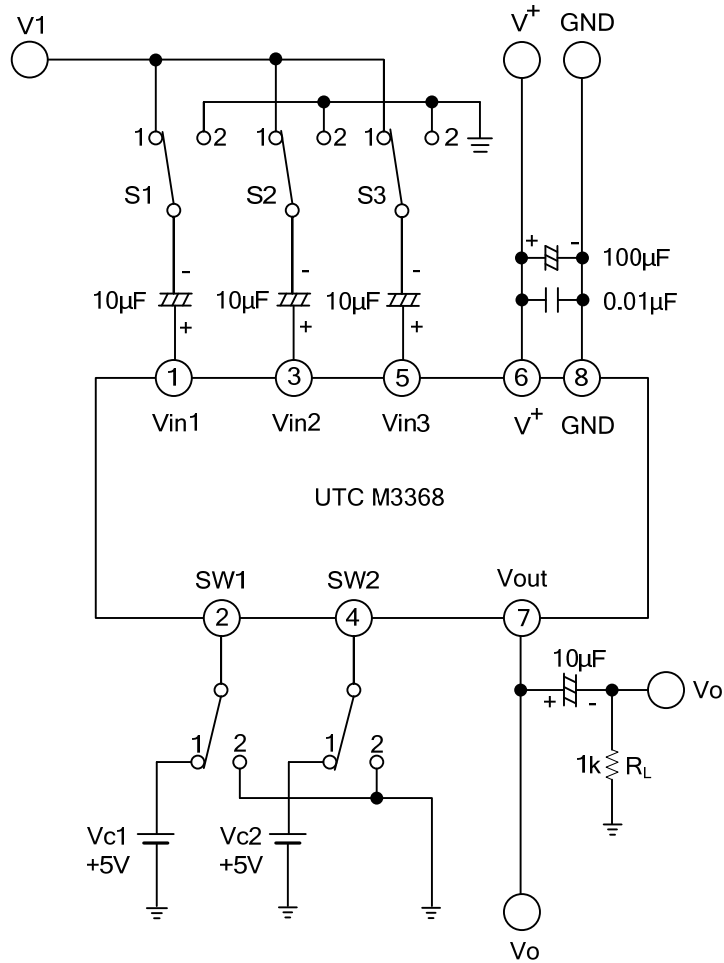

■ DC VOLTAGE EACH TERMINAL (Typ. on Test Circuit $T_A=25^\circ\text{C}$)

Terminal Name	VIN1	SW1	VIN2	SW2	VIN3	V ⁺	VOUT	GND
DC Voltage	$\frac{2}{5}V^+$		$\frac{2}{5}V^+$		$\frac{2}{5}V^+$		$\frac{2}{5}V^+ - 0.7$	

UTC assumes no responsibility for equipment failures that result from using products at values that exceed, even momentarily, rated values (such as maximum ratings, operating condition ranges, or other parameters) listed in products specifications of any and all UTC products described or contained herein. UTC products are not designed for use in life support appliances, devices or systems where malfunction of these products can be reasonably expected to result in personal injury. Reproduction in whole or in part is prohibited without the prior written consent of the copyright owner. The information presented in this document does not form part of any quotation or contract, is believed to be accurate and reliable and may be changed without notice.