



## DESCRIPTION

The AP8012 consists of a Pulse Width Modulator (PWM) controller and a power MOSFET, specifically designed for a high performance off-line converter with minimal external components. AP8012 offers complete protection coverage with automatic self-recovery feature including Cycle-by-Cycle current limiting (OCP), over temperature protection (OTP), under-voltage Lockout protection(UVLO) ,  $V_{DD}$  over-voltage protection(OVP), and soft-start. Burst mode operation and device very low consumption helps to meet the standby energy saving regulations. Excellent EMI performance is achieved with frequency modulation. The device consists of a high voltage start-up circuit in order to reduce the system set-up time. The device provides an advanced platform well suited for low standby-power and cost-effective flyback converters.

The AP8012 is available in DIP8 and SOP8 packages.

## ORDERING INFORMATION

Package Type	Part Number	
DIP8 SPQ: 50pcs/Tube	P8	AP8012P8U
		AP8012P8VU
SOP8 SPQ: 4,000pcs/Reel	M8	AP8012M8R
		AP8012M8VR
Note	V: Halogen free Package R: Tape & Reel U: Tube	
AiT provides all RoHS products		

## FEATURES

- Integrated 800V avalanche-rugged power MOSFET
- 85V to 265V wide range AC voltage input
- Semi enclosed steady output power 6W(DIP8)@85~265V<sub>AC</sub>
- Frequency modulation for low EMI
- Burst-mode Operation
- Built-in Soft Start
- Internal HV Start-up Circuit
- Excellent Protection :  
Over Current Protection (OCP)  
Over Temperature Protection (OTP)  
 $V_{DD}$  over-voltage protection (OVP)
- Available in DIP8 and SOP8 Packages

## APPLICATION

- Electromagnetic Oven power supplies
- Small household application power supplies (Coffee machine, Electric kettle, etc.)

## TYPICAL APPLICATION

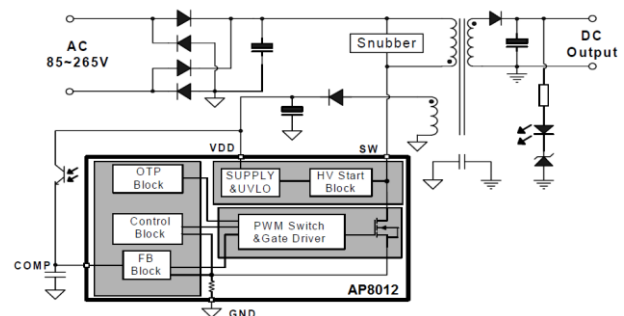



**PIN DESCRIPTION**

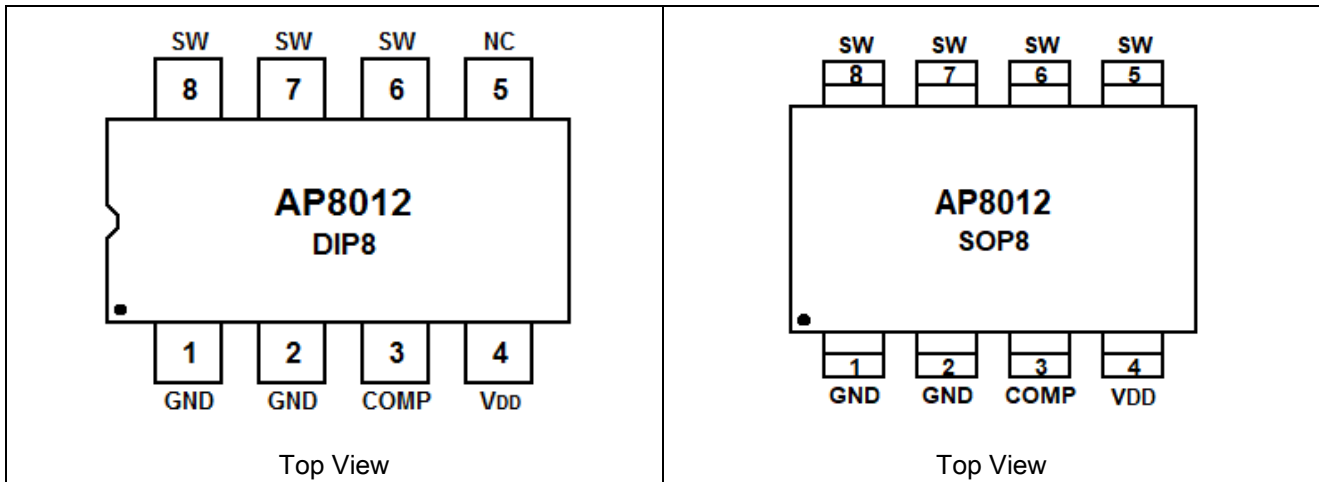

Pin #		Symbol	Function
DIP8	SOP8		
1, 2	1, 2	GND	Ground
3	3	COMP	Voltage feedback. By connecting a opto-coupler to close the control loop and achieve the regulation.
4	4	V <sub>DD</sub>	Positive Supply voltage Input.
5	-	NC	No connection
6,7,8	5,6,7,8	SW	The SW pin is designed to connect directly to the primary lead of the transformer.

**TYPICAL POWER**

Package	AC line Voltage	continuous power <sup>NOTE1</sup>	Peak power <sup>NOTE2</sup>
DIP8	85-265 V <sub>AC</sub>	6W(12V500mA)	8.4W(12V700mA)
SOP8	85-265 V <sub>AC</sub>	3.6W(12V300mA)	6W(12V500mA)

NOTE1: Maximum output power in a semi enclosed design measured at 75°C ambient temperature, Duration:2 hours

NOTE2: Peak power in a semi enclosed design measured at 75°C ambient temperature, Duration:1 min



## ABSOLUTE MAXIMUM RATINGS

Supply Voltage Pin $V_{DD}$	-0.3V~45V
High-Voltage Pin, SW	-0.3V~750V
COMP	-0.3V~7V
Junction Temperature	-40°C~150°C
Storage Temperature	-55°C~150°C
Lead Temperature (Soldering, 10secs)	260°C
$R_{\theta JC}$ , Package Thermal Resistance	SOP8 80°C/W
$R_{\theta JC}$ , Package Thermal Resistance	DIP8 40°C/W
Electrostatic Discharge Human Body Mode (HBM, ESDA/JEDEC JDS-001-2014)	±4kV
SD Voltage Protection <sup>NOTE3</sup> (Air discharge to pins of AP8012 with ESD Generator)	8kV
Drain Pulse Current (Tpulse=100us )	2A

Stress beyond above listed "Absolute Maximum Ratings" may lead permanent damage to the device. These are stress ratings only and operations of the device at these or any other conditions beyond those indicated in the operational sections of the specifications are not implied. Exposure to absolute maximum rating conditions for extended periods may affect device reliability.

NOTE3: Enterprise internal standards, for reference only.

## ELECTRICAL CHARACTERISTICS

$T_J = 25^\circ\text{C}$ ,  $V_{DD} = 15\text{V}$ , unless otherwise specified

### Power section

Parameter	Symbol	Conditions	Min.	Typ.	Max	Unit
VDMOS Breakdown Voltage	$B_{VDSS}$	$I_{SW} = 250\mu\text{A}$	750	820	-	V
Static Drain-Source off Current	$I_{OFF}$	$V_{SW} = 550\text{V}$	-	-	100	$\mu\text{A}$
Static Drain-Source on Resistance	$R_{DSON}$	$I_{SW} = 400\text{mA}$ , $T_J = 25^\circ\text{C}$	-	18	-	$\Omega$

### Control section

Parameter	Symbol	Conditions	Min.	Typ.	Max	Unit
<b>UVLO SECTION</b>						
$V_{CC}$ Start Threshold Voltage	$V_{START}$	$V_{COMP} = 0\text{V}$	13	14.5	16	V
$V_{CC}$ Stop Threshold Voltage	$V_{STOP}$	$V_{COMP} = 0\text{V}$	7	8	9	V
$V_{CC}$ Threshold Hysteresis	$V_{HYS}$		-	6.5	-	V
$V_{DD}$ Reset Voltage	$V_{RST}$		5.5	6.0	6.5	V



Parameter	Symbol	Conditions	Min.	Typ.	Max	Unit
<b>OSCILLATOR SECTION</b>						
Initial Accuracy	$f_{OSC}$	$T_A = 25^\circ C$	40	45	50	kHz
Frequency Variation	$f_D$		-	$\pm 5$	-	kHz
Modulation Frequency	$f_M$		-	167	-	Hz
Maximum Duty Cycle	$D_{MAX}$		65	80	90	%
<b>FEEDBACK SECTION</b>						
Feedback Shutdown Current	$I_{COMP}$		-	1.2	-	mA
COMP Pin Input Impedance	$R_{COMP}$		-	1.15	-	k $\Omega$
<b>CURRENT LIMIT(SELF-PROTECTION) SECTION</b>						
Peak Current Limit	$I_{LIM}$	$T_A = 25^\circ C$	0.44	0.55	0.66	A
Minimum Turn On Time	$t_{LEB}$	LEB time	-	350	-	ns
Soft-start Time	$t_{SS}$		-	10	-	ms
Peak Drain Current During Burst Mode	$I_{D\_BM}$		-	100	-	mA
<b>PROTECTION SECTION</b>						
Thermal Shutdown Temperature	$T_{SD}$		140	170	-	$^\circ C$
Thermal Shutdown Hysteresis	$T_{HYST}$		-	30	-	$^\circ C$
<b>SUPPLY CURRENT SECTION</b>						
Startup Charging Current (SW pin)	$I_{CH}$	$V_{DRAIN} = 105V, V_{COMP} = GND, V_{DD} = 12V$	-	-1.2	-	mA
Operating Supply Current, Switching	$I_{DD}$	$V_{DD} = 16V, V_{COMP} = 0V$	-	0.6	-	mA
Operating Voltage Range	$V_{DD}$	After turn-on	10	-	35	V
$V_{DD}$ Over Voltage	$V_{OVP}$		37	40	43	V
Operating Supply Current with $V_{DD} < V_{STOP}$	$I_{DD\_OFF}$	$V_{DD} = 6V$	100	-	400	$\mu A$



## TYPICAL PERFORMANCE CHARACTERISTICS

1.  $R_{DS(on)}$  vs.  $T_J$

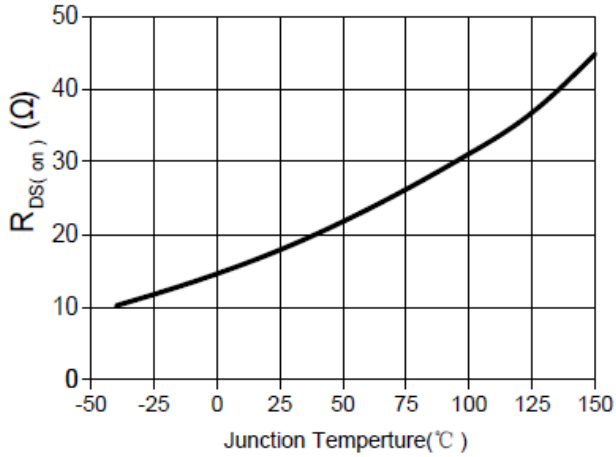

2.  $B_{VDSS}$  vs.  $T_J$

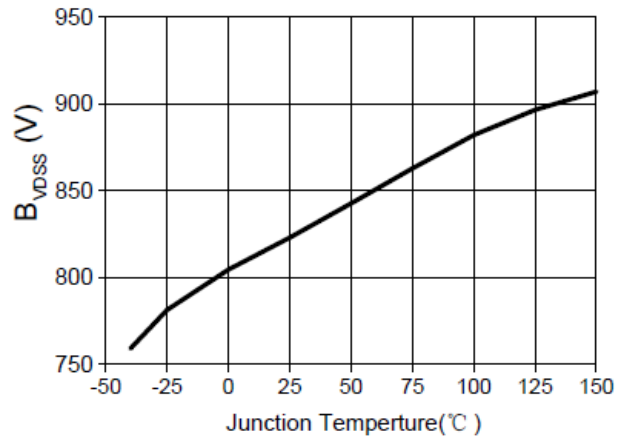

3.  $V_{START}$  vs.  $T_J$

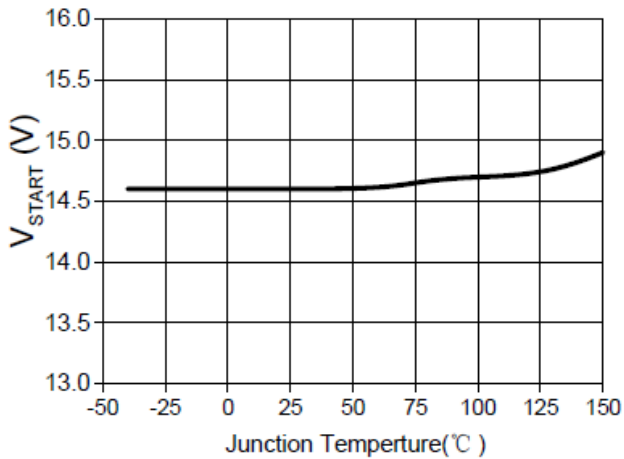

4.  $V_{STOP}$  vs.  $T_J$

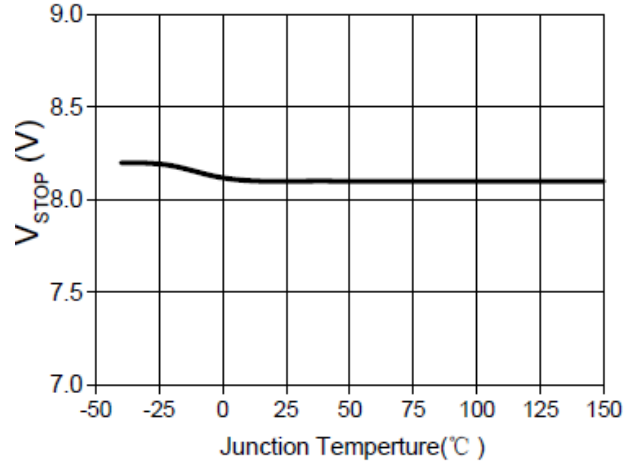

5.  $V_{OVP}$  vs.  $T_J$

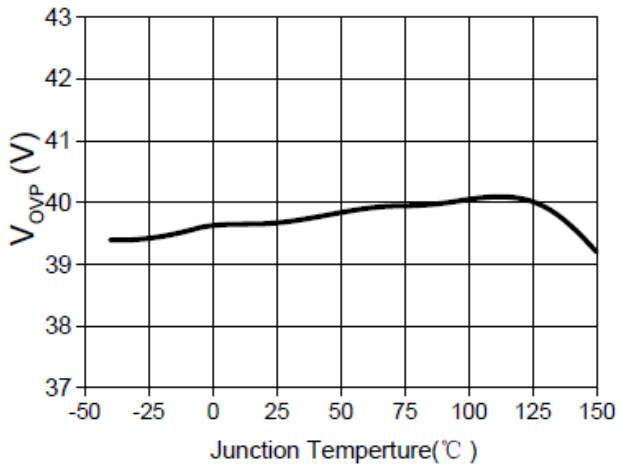

6.  $f_{OSC}$  vs.  $T_J$

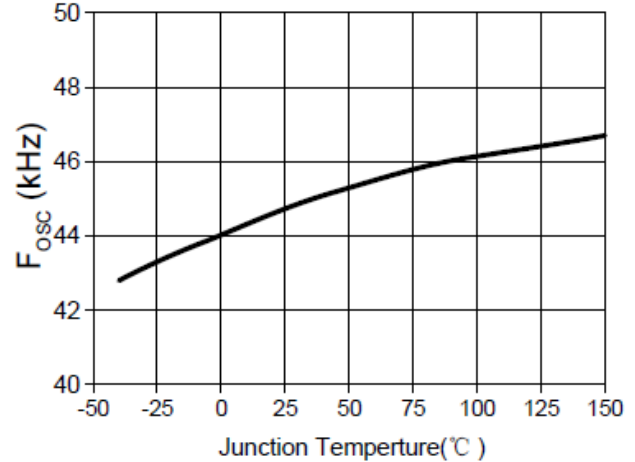



**TYPICAL CIRCUIT**

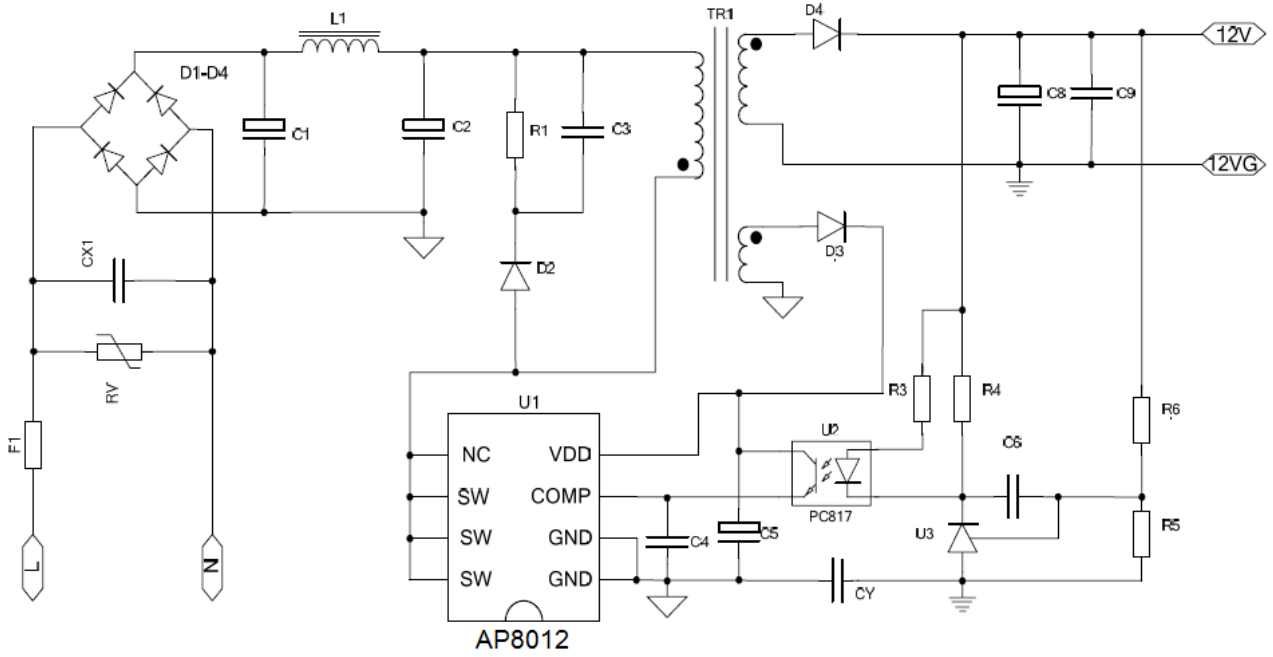



## DETAILED INFORMATION

### Functional Description

#### Startup

This device includes a high voltage start up current source connected on the SW of the device. As soon as a voltage is applied on the input of the converter, this start up current source is activated and to charge the  $V_{DD}$  capacitor as long as  $V_{DD}$  is lower than  $V_{START}$ . When reaching  $V_{START}$ , the start up current source is cut off and  $V_{DD}$  is sourced by auxiliary side. As  $V_{DD}$  falls below  $V_{STOP}$ , the HV-Start circuit won't work immediately until  $V_{DD}$  is lower than  $V_{RST}$ .

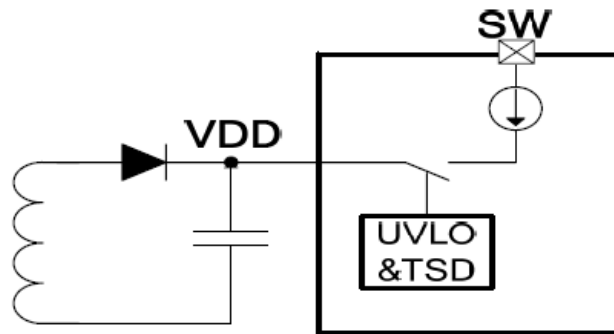

Fig 1. Startup circuit

#### Soft-start up

In the process of start up, the current of drain increases to maximum limitation step by step. As a result, it can reduce the stress of secondary diode greatly and help to prevent the transformer turning into the saturation states. Typically, the duration of soft-start is 10ms.

#### Gate driver

The internal power MOSFET in AP8012 is driven by a dedicated gate driver for power switch control. Too weak the gate driver strength results in higher conduction and switch loss of MOSFET while too strong gate drive results in worse EMI.

A good tradeoff is achieved through the built-in totem pole gate design with proper output strength and dead time. The good EMI system design and low idle loss is easier to achieve with this dedicated control scheme.

#### Oscillator

The switching frequency of AP8012 is internally fixed at 45 kHz. No external frequency setting components are required for PCB design.

The frequency modulation is implemented in AP8012. So that, it minimizes the conduction band EMI and therefore eases the system design because the tone energy could be spread out.



### Feed-back

A feedback pin controls the operation of the device. Unlike conventional PWM control circuits which use a voltage input, the COMP pin is sensitive to current. Fig. 2 presents the internal current mode structure. The Power MOSFET delivers a sense current which is proportional to the main current. R2 receives this current and the current coming from the COMP pin. The voltage across R2 ( $V_{R2}$ ) is then compared to a fixed reference voltage. The MOSFET is switched off when  $V_{R2}$  equals the reference voltage.

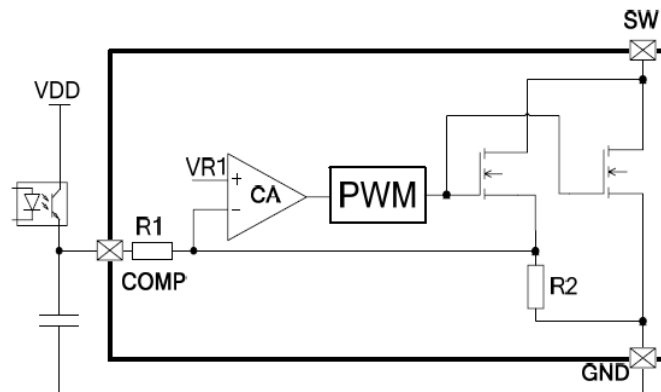

Fig 2. Feedback circuit

### Leading Edge Blanking (LEB)

At the instant the internal Sense FET is turned on, there usually exists a high current spike through the Sense FET, caused by the primary side capacitance and secondary side rectifier diode reverse recovery. Excessive voltage across the sense resistor would lead to false feedback operation in the current mode PWM control. To counter this effect, the device employs a leading edge blanking (LEB) circuit. This circuit inhibits the PWM comparator for a short time (typically 350ns) after the Sense FET is turned on.

### Under Voltage Lock Out

Once fault condition occurs, switching is terminated and the Sense FET remains off. This causes  $V_{DD}$  to fall. When  $V_{DD}$  reaches the  $V_{DD}$  reset voltage, 6V, the protection is reset and the internal high voltage current source charges the  $V_{DD}$  capacitor. When  $V_{DD}$  reaches the UVLO start voltage, 14.5V, the device resumes its normal operation. In this manner, the auto-restart can alternately enable and disable the switching of the power Sense FET until the fault condition is eliminated.

### Thermal Shutdown (TSD)

The Sense FET and the control IC are integrated in the same chip, making it easier for the control IC to detect the temperature of the Sense FET. When the temperature exceeds approximately 170°C, thermal shutdown is activated, the device turn off the Sense FET. The device will go back to work when the lower threshold temperature about 140°C is reached.





**PACKAGE INFORMATION**

Dimension in DIP8 (Unit: mm)

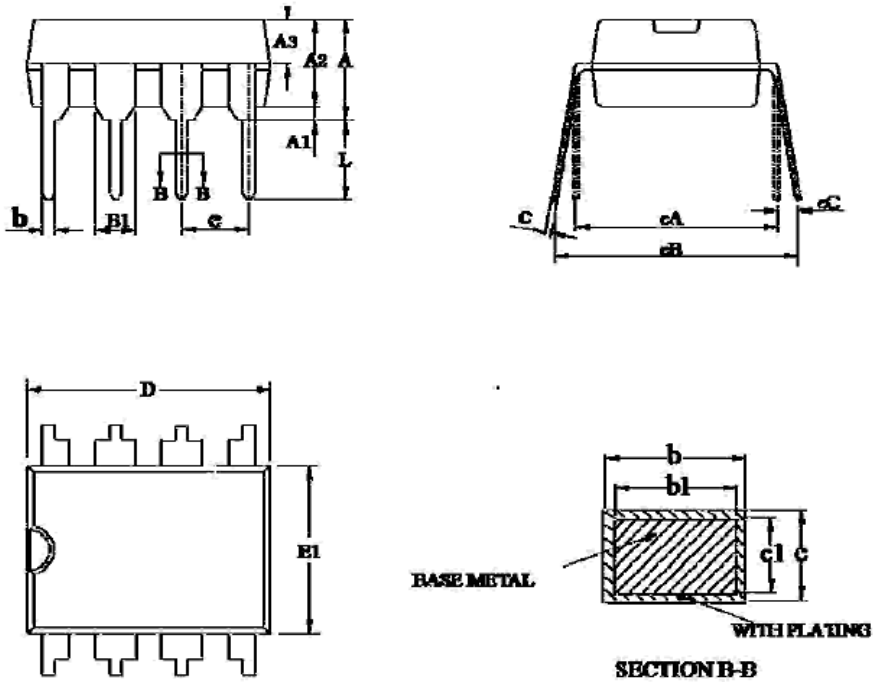

Symbol	Min	Max
A	3.600	4.000
A1	0.510	-
A2	3.000	3.400
A3	1.550	1.650
b	0.440	0.530
b1	0.430	0.480
B1	1.520BSC	
c	0.240	0.320
c1	0.230	0.270
D	9.050	9.450
E1	6.150	6.550
e	2.540BSC	
eA	7.620BSC	
eB	7.620	9.300
eC	0.000	0.840
L	3.000	-



Dimension in SOP8 (Unit: mm)

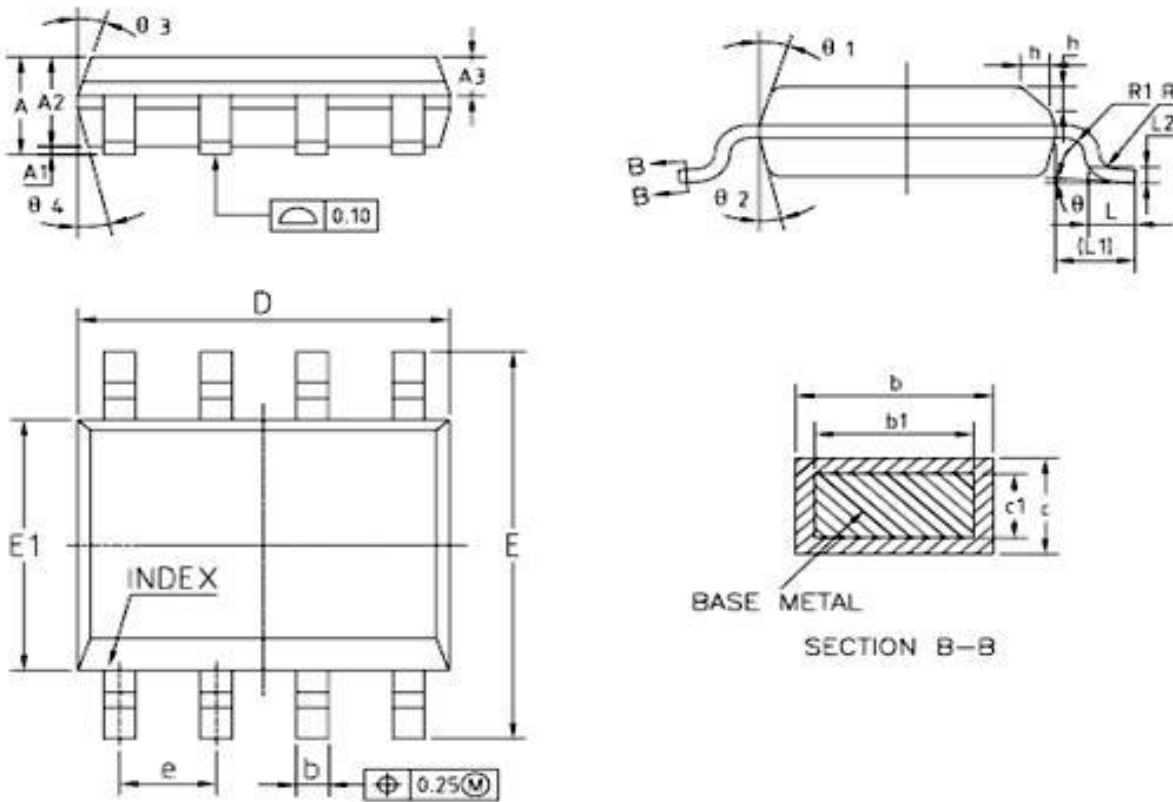

Symbol	Min	Max	Symbol	Min	Max
A	1.350	1.750	L	0.450	0.800
A1	0.100	0.250	L1	1.040REF	
A2	1.250	1.650	L2	0.250BSC	
A3	0.500	0.700	R	0.070	-
b	0.380	0.510	R1	0.070	-
b1	0.370	0.470	h	0.300	0.500
c	0.170	0.250	theta	0°	8°
c1	0.170	0.230	theta1	15°	19°
D	4.800	5.000	theta2	11°	15°
E	5.800	6.200	theta3	15°	19°
E1	3.800	4.000	theta4	11°	15°
e	1.270BSC				



## IMPORTANT NOTICE

AiT Semiconductor Inc. (AiT) reserves the right to make changes to any its product, specifications, to discontinue any integrated circuit product or service without notice, and advises its customers to obtain the latest version of relevant information to verify, before placing orders, that the information being relied on is current.

AiT Semiconductor Inc.'s integrated circuit products are not designed, intended, authorized, or warranted to be suitable for use in life support applications, devices or systems or other critical applications. Use of AiT products in such applications is understood to be fully at the risk of the customer. As used herein may involve potential risks of death, personal injury, or server property, or environmental damage. In order to minimize risks associated with the customer's applications, the customer should provide adequate design and operating safeguards.

AiT Semiconductor Inc. assumes to no liability to customer product design or application support. AiT warrants the performance of its products of the specifications applicable at the time of sale.