

AN8473SA

Spindle motor driver IC for optical disk

Overview

The AN8473SA is an optical disk driver IC, featuring direct PWM drive, DMOS power drive, low ON resistance of output power MOS and 120° of duty-factor.

Features

- $R_{ON} = 0.5 \Omega$ (for both upper and lower)
- 5 V single power source
- Circuit current 7 mA (including step-up circuit current)

Applications

- Optical disk

Block Diagram

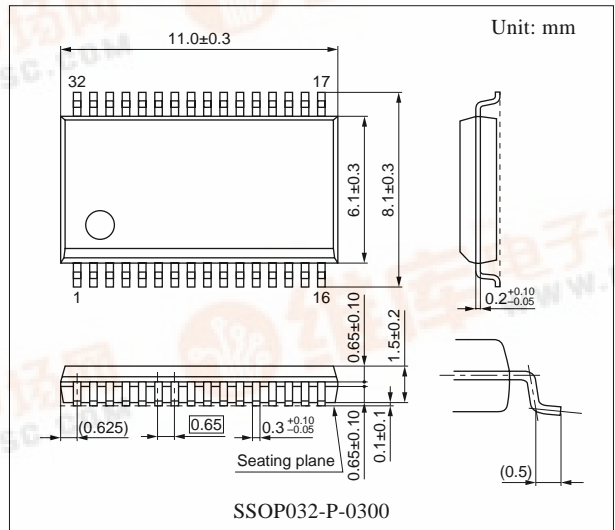
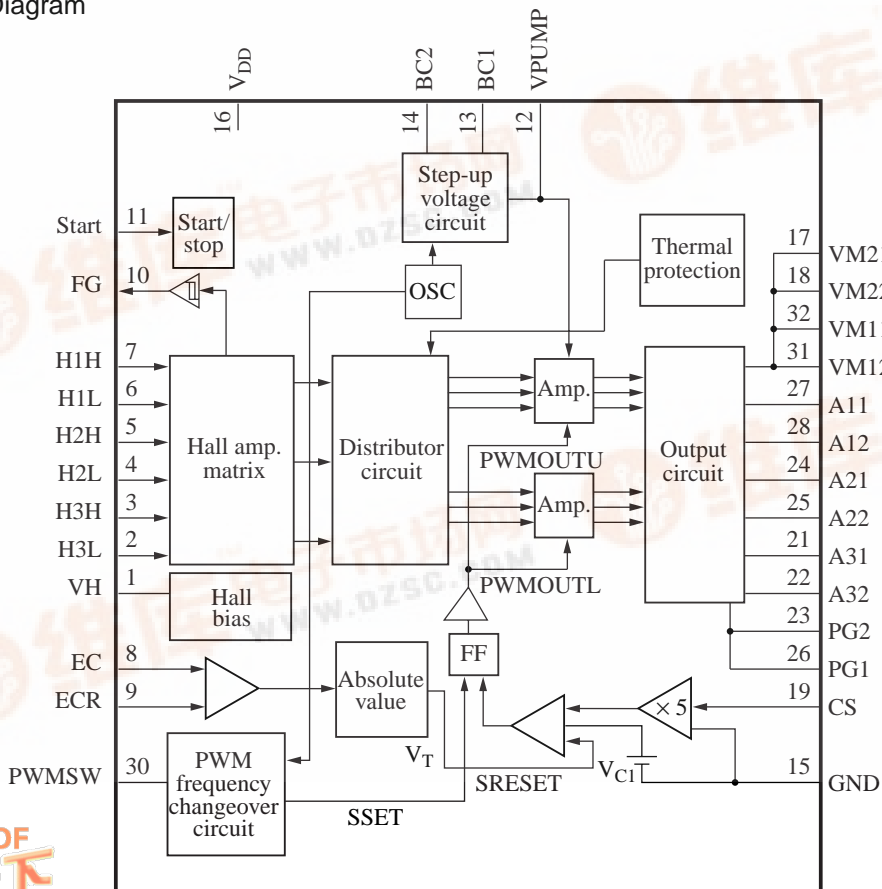

■ Pin Descriptions

Pin No.	Symbol	Description	Pin No.	Symbol	Description
1	VH	Hall bias pin	17	VM21	Motor supply voltage pin 2
2	H3L	Hall element-3 negative input pin	18	VM22	Motor supply voltage pin 2
3	H3H	Hall element-3 positive input pin	19	CS	Current det. pin
4	H2L	Hall element-2 negative input pin	20	N.C.	N.C.
5	H2H	Hall element-2 positive input pin	21	A31	Drive output 3
6	H1L	Hall element-1 negative input pin	22	A32	Drive output 3
7	H1H	Hall element-1 positive input pin	23	PG2	Power current det. pin 2
8	EC	Torque command input pin	24	A21	Drive output 2
9	ECR	Torque command reference input pin	25	A22	Drive output 2
10	FG	FG signal output pin	26	PG1	Power current det. pin 1
11	Start	Start/stop changeover pin	27	A11	Drive output 1
12	VPUMP	Booster pin	28	A12	Drive output 1
13	BC1	Booster capacitor connection pin 1	29	N.C.	N.C.
14	BC2	Booster capacitor connection pin 2	30	PWMSW	PWM frequency changeover pin
15	GND	Ground pin	31	VM12	Motor supply voltage pin 1
16	V _{DD}	Supply voltage pin	32	VM11	Motor supply voltage pin 1

■ Absolute Maximum Ratings

Parameter	Symbol	Rating	Unit
Supply voltage *2	V _{DD}	6.5	V
	V _{M11, 12}		
	V _{M21, 22}		
Drive output voltage *5	V _(m)	15	V
Control signal input voltage *6	V _(n)	0 to V _{DD}	V
Supply current	I _{DD}	30	mA
Drive output current *4	I _(o)	±1 200	mA
Hall bias current *7	I _{HB(n)}	30	mA
Power dissipation *3	P _D	293	mW
Operating ambient temperature *1	T _{opr}	-30 to +85	°C
Storage temperature *1	T _{stg}	-55 to +150	°C

Note) Do not apply external currents or voltages to any pins not specifically mentioned.

For circuit currents, '+' denotes current flowing into the IC, and '-' denotes current flowing out of the IC.

*1: Except for the operating ambient temperature and storage temperature, all ratings are for T_a = 25°C.

*2: The voltage in the step-up voltage circuit exceeds the supply voltage.

For the allowable value of the step-up voltage, refer to "■ Electrical Characteristics".

*3: The power dissipation shown is the value of independent IC without a heat sink at T_a = 70°C. Refer to the P_D — T_a curves of the "■ Application Notes" for details.

*4: o = 17, 18, 21, 22, 23, 24, 25, 26, 27, 28, 31, 32

*5: m = 21, 22, 24, 25, 27, 28

*6: n = 2, 3, 4, 5, 6, 7, 8, 9, 11, 30

*7: n = 1

■ Recommended Operating Range

Parameter	Symbol	Range	Unit
Supply voltage	V_{DD}	4.5 to 5.5	V
	$V_{M11, 12}$		
	$V_{M21, 22}$		

■ Electrical Characteristics at $T_a = 25^\circ\text{C}$

Parameter	Symbol	Conditions	Min	Typ	Max	Unit
Overall						
Circuit current 1	I_{DD1}	$V_{DD} = 5\text{ V}$ in power save mode	—	0	0.2	mA
Circuit current 2	I_{DD2}	$V_{DD} = 5\text{ V}$ including step-up circuit	—	7	14	mA
Start/stop						
Start voltage	V_{START}	Voltage with which a circuit operates at $V_{DD} = 5\text{ V}$ and $L \rightarrow H$	2.7	—	—	V
Stop voltage	V_{STOP}	Voltage with which a circuit becomes off at $V_{DD} = 5\text{ V}$ and $H \rightarrow L$	—	—	0.7	V
Hall bias						
Hall bias voltage	V_{HB}	$V_{DD} = 5\text{ V}$, $I_{HB} = 20\text{ mA}$	0.7	1.2	1.6	V
Hall amplifier						
Input bias current	I_{BH}	$V_{DD} = 5\text{ V}$	—	1	5	μA
In-phase input voltage range	V_{HBR}	$V_{DD} = 5\text{ V}$, except for H2H, H2L	1.5	—	4.0	V
Minimum input level	V_{INH}	$V_{DD} = 5\text{ V}$	60	—	—	mV[p-p]
Torque command						
In-phase input voltage range	EC	$V_{DD} = 5\text{ V}$	0.5	—	3.9	V
Offset voltage	EC_{OF}	$V_{DD} = 5\text{ V}$	-100	0	100	mV
Dead zone	EC_{DZ}	$V_{DD} = 5\text{ V}$	0	75	150	mV
Input current	EC_{IN}	$V_{DD} = 5\text{ V}$, $EC = ECR = 2.5\text{ V}$	-5	-1	—	μA
Input/output gain	A_{CS}	$V_{DD} = 5\text{ V}$, $R_{CS} = 0.33\ \Omega$	0.36	0.48	0.60	A/V
Output						
High-level output saturation voltage	V_{OH}	$V_{DD} = 5\text{ V}$, $I_O = -500\text{ mA}$	—	0.15	0.30	V
Low-level output saturation voltage	V_{OL}	$V_{DD} = 5\text{ V}$, $I_O = 500\text{ mA}$	—	0.15	0.30	V
Torque limit current	I_{TL}	$V_{DD} = 5\text{ V}$, $R_{CS} = 0.33\ \Omega$	455	570	685	mA
FG						
FG output high-level	FG_H	$V_{DD} = 5\text{ V}$, $I_{FG} = -0.01\text{ mA}$	3	—	—	V
FG output low-level	FG_L	$V_{DD} = 5\text{ V}$, $I_{FG} = 0.01\text{ mA}$	—	—	0.5	V
In-phase input voltage range	V_{FGR}	$V_{DD} = 5\text{ V}$	1.5	—	3.0	V
FG hysteresis width	H_{FG}	$V_{DD} = 5\text{ V}$	5	10	20	mV
Step-up circuit						
Step-up voltage	V_{PUMP}	$V_{DD} = 5\text{ V}$	7	—	10	V

■ Electrical Characteristics at $T_a = 25^\circ\text{C}$ (continued)

Parameter	Symbol	Conditions	Min	Typ	Max	Unit
PWM oscillation changeover						
Input high-level	PWM_{H}	$V_{\text{DD}} = 5\text{ V}$	4.5	—	—	V
Input low-level	PWM_{L}	$V_{\text{DD}} = 5\text{ V}$	—	—	0.5	V

• Design reference data

Note) The characteristics listed below are theoretical values based on the IC design and are not guaranteed.

Parameter	Symbol	Conditions	Min	Typ	Max	Unit
PWM oscillation changeover						
PWM frequency high-level	f_{PWMH}	$V_{\text{DD}} = 5\text{ V}$, $\text{PWMSW} = \text{Low}$	—	80	—	kHz
PWM frequency low-level	f_{PWML}	$V_{\text{DD}} = 5\text{ V}$, $\text{PWMSW} = \text{High}$	—	40	—	kHz
Thermal protection						
Thermal protection operating temperature	T_{SDON}	$V_{\text{DD}} = 5\text{ V}$	—	150	—	$^\circ\text{C}$
Thermal protection hysteresis width	ΔT_{SD}	$V_{\text{DD}} = 5\text{ V}$	—	40	—	$^\circ\text{C}$

■ Usage Notes

- Prevent this IC from being line-to-ground fault.

(To be concrete, do not short-circuit any of A31 (pin 21), A32 (pin 22), A21 (pin 24), A22 (pin 25), A11 (pin 27) and A12 (pin 28) with GND pin (pin 15).)

- Be careful of the following three pins because their static breakdown voltages are low. ($C = 200\text{ pF}$, $R = 0\ \Omega$)

Pin 23: breakdown at 120 V

Pin 26: breakdown at 120 V

■ Application Notes

- $P_{\text{D}} - T_a$ curves of SSOP032-P-0300

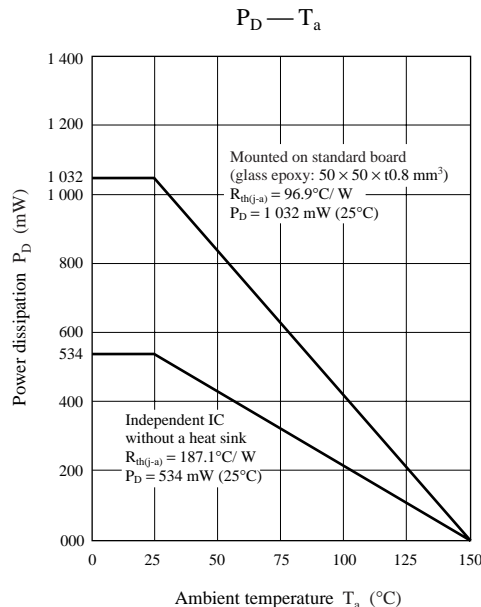

■ Application Notes (continued)

- Phase conditions between Hall input and output current

Phase of Hall pin			
	H1H	H2H	H3H
A	H	ML	ML
B	MH	L	MH
C	ML	ML	H
D	L	MH	MH
E	ML	H	ML
F	MH	MH	L

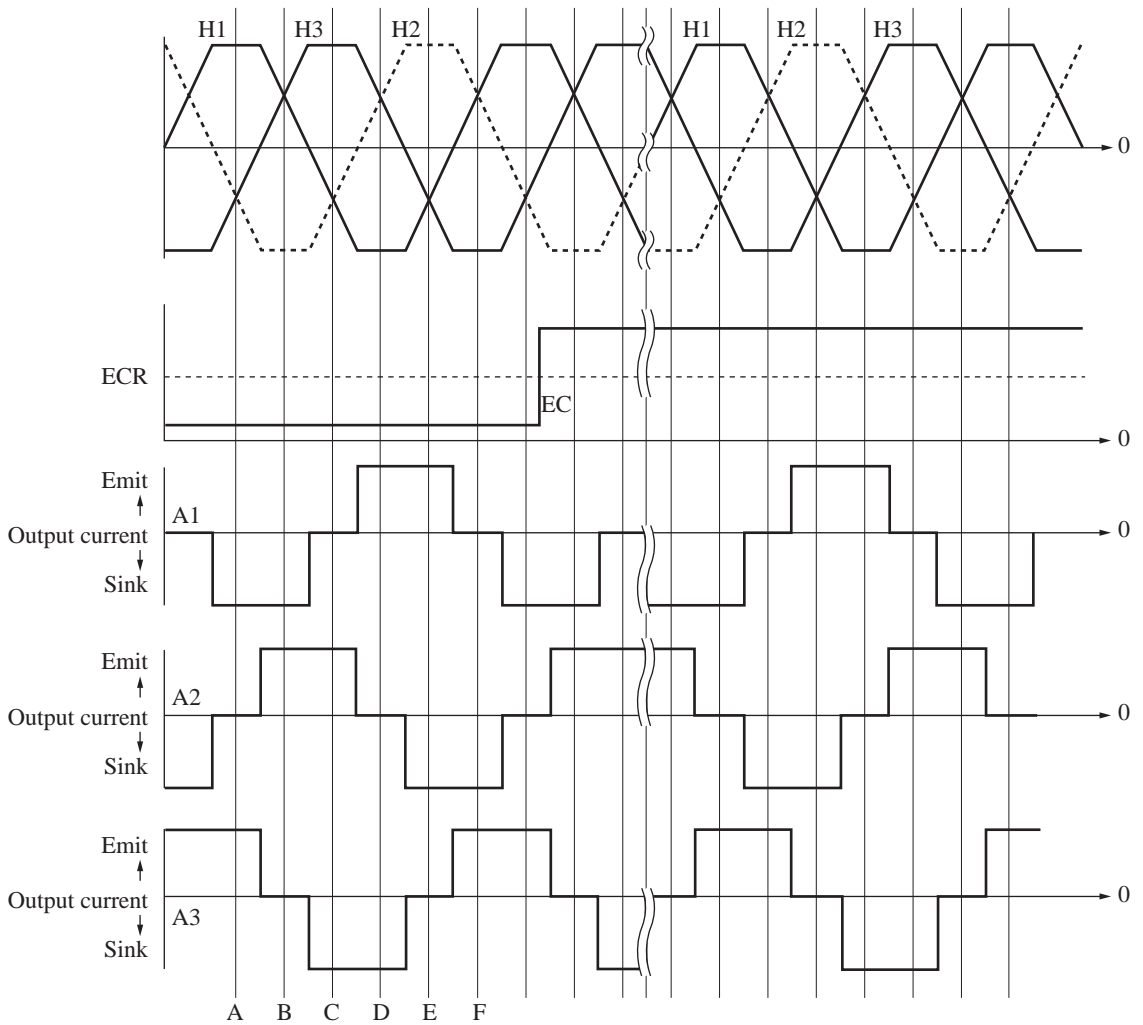

■ Application Circuit Example

(Check the stipulated value of electrical characteristics and then determine resistance value.)

