

isc N-Channel MOSFET Transistor

2SK2056

DESCRIPTION

- Drain Current $-I_D = 4A @ T_C = 25^\circ C$
- Drain Source Voltage-
: $V_{DSS} = 800V(\text{Min})$
- Fast Switching Speed

APPLICATIONS

- Switching regulators
- General purpose power amplifier

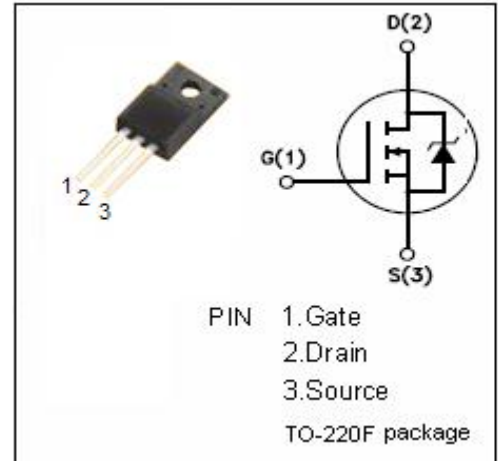

ABSOLUTE MAXIMUM RATINGS($T_a = 25^\circ C$)

SYMBOL	ARAMETER	VALUE	UNIT
V_{DSS}	Drain-Source Voltage ($V_{GS} = 0$)	800	V
V_{GS}	Gate-Source Voltage	± 30	V
I_D	Drain Current-continuous@ $TC = 25^\circ C$	4	A
$I_{D(puls)}$	Pulsed Drain Current	16	A
P_{tot}	Total Dissipation@ $TC = 25^\circ C$	40	W
T_j	Max. Operating Junction Temperature	150	$^\circ C$
T_{stg}	Storage Temperature Range	-55~150	$^\circ C$

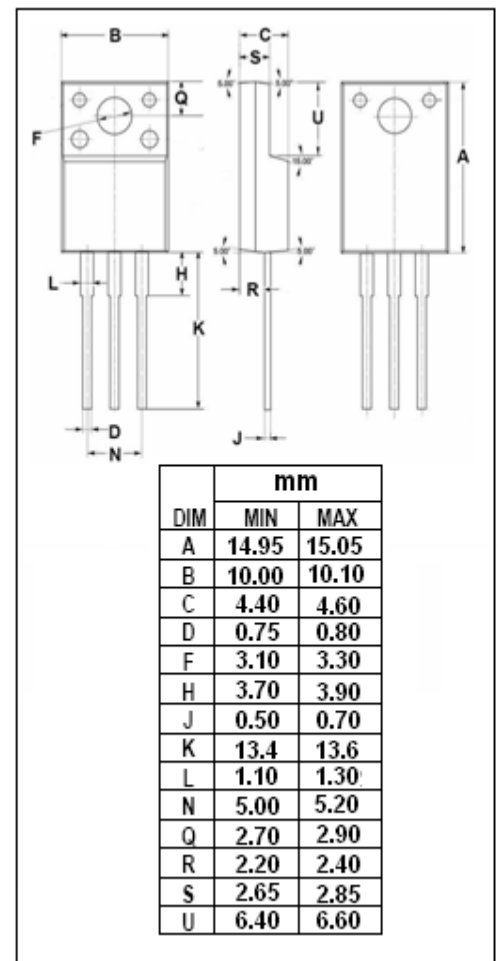

isc N-Channel Mosfet Transistor**2SK2056**• ELECTRICAL CHARACTERISTICS ($T_C=25^\circ\text{C}$)

SYMBOL	PARAMETER	CONDITIONS	MIN	TYPE	MAX	UNIT
$V_{(BR)DSS}$	Drain-Source Breakdown Voltage	$V_{GS}=0; I_D=1\text{mA}$	800			V
$V_{GS(th)}$	Gate Threshold Voltage	$V_{DS}=V_{GS}; I_D=1\text{mA}$	1.5		3.5	V
$R_{DS(on)}$	Drain-Source On-Resistance	$V_{GS}=10\text{V}; I_D=2\text{A}$		1.0	1.2	Ω
I_{GSS}	Gate-Body Leakage Current	$V_{GS}= \pm 30\text{V}; V_{DS}=0$			± 100	nA
I_{DSS}	Zero Gate Voltage Drain Current	$V_{DS}=800\text{V}; V_{GS}=0$			500	μA