

Structure : Silicon Monolithic Integrated Circuit  
 Product name : 6 Outputs Video Driver for DVD Applications

Type : **BH7868FS**

Features :

- 1) Built-in LPF with characteristics suited to DVD players and recorders
- 2) Built-in 6-output video driver for Y signal, C signal, Y/C MIX signal, and Py/G, Pb/B, Pr/R signals
- 3) Three circuits drivable for Y signal, C signal, and Y/C MIX signal, and two circuits for Py/G, Pb/B, Pr/R signals
- 4) Built-in sag correction circuit
- 5) Built-in S1/S2 output function

○Absolute Maximum Ratings (Ta=25°C)

Parameter	Symbol	Limits	Unit
Supply voltage	VccMAX	6.0	V
Power dissipation	Pd	0.95 *1	W
Operating temperature	Topr	-40 ~ +70	°C
Storage temperature	Tstg	-55 ~ +150	°C

\*1 Deratings in done at 7.6mW/°C above Ta=25°C  
 (When mounted on a 70mm × 70mm × 1.6mm PCB board).

○Operating Range (Ta=25°C)

Parameter	Symbol	Limits	Unit
Supply voltage	Vcc	+4.5 ~ +5.5	V

\* This product is not designed for protection against radioactive rays.

Application example

The product described in this specification is designed to be used with ordinary electronic equipment or devices (such as audio-visual equipment, office-automation equipment, communications devices, electrical appliances, and electronic toys). Should you intend to use this product with equipment or devices which require an extremely high level or reliability and the malfunction of which would directly endanger human life (such as medical instruments, transportation equipment, aerospace machinery, nuclear-reactor controllers, fuel controllers and other safety devices), please be sure to consult with our sales representative in advance.

OElectrical characteristics (1/2) (Unless otherwise noted, Ta= 25°C, Vcc=5.0V)

Parameter	Symbol	Specifications			Unit	Conditions
		Min.	TYP.	Max.		
Circuit current 1	I <sub>CC1</sub>	—	90	110	mA	No signal 6ch Active MODE
Circuit current 2	I <sub>CC2</sub>	—	45	59	mA	No signal Mute1 ON (C,Y,CV channel)
Circuit current 3	I <sub>CC3</sub>	—	45	59	mA	No signal Mute2 ON
Circuit current 4	I <sub>CC4</sub>	—	5	7.5	mA	No signal Mute1 & Mute2 ON
Maximum output level 1	V <sub>OM1</sub>	2.6	3.0	—	V <sub>pp</sub>	f=10 kHz, THD = 1.0% C, Py/G(BIAS), Pb/B, Pr/R
Maximum output level 2	V <sub>OM2</sub>	2.6	2.8	—	V <sub>pp</sub>	f=10 kHz, THD = 1.0% CV,Y,MIX, Py,/G(CLAMP)
Voltage gain C	G <sub>VC</sub>	5.7	6.0	6.3	dB	CIN : f=3.58MHz、1Vpp
MIX (C)	G <sub>VMIXC</sub>	5.7	6.0	6.3	dB	CIN : f=3.58MHz、1Vpp
MIX (Y)	G <sub>VMIXY</sub>	5.7	6.0	6.3	dB	YIN : f=1MHz、1Vpp
CV	G <sub>VCVIN</sub>	5.7	6.0	6.3	dB	YIN : f=1MHz、1Vpp
Y	G <sub>VY</sub>	5.7	6.0	6.3	dB	YIN : f=1MHz、1Vpp
Py/G (CLAMP/BIAS)	G <sub>VPY</sub>	5.7	6.0	6.3	dB	Py/G IN : f=1MHz、1Vpp
Pb/B	G <sub>VPb</sub>	5.7	6.0	6.3	dB	Pb/B IN : f=1MHz、1Vpp
Pr/R	G <sub>VPr</sub>	5.7	6.0	6.3	dB	Pr/R IN : f=1MHz、1Vpp
Frequency characteristics 1 (CIN, CVIN, YIN)	f11	-1.5	-0.5	0.5	dB	fin=100k/6.75MHz,1Vpp
	f12	—	-33	-27	dB	fin=100k/27MHz、1Vpp
Frequency characteristics 1 (Py/G IN, Pb/B IN, Pr/R IN)	f21	-1.5	-0.5	0.5	dB	fin=100k/13.5MHz、1Vpp
	f22	—	-28	-22	dB	fin=100k/54MHz、1Vpp
Differential Gain	D <sub>G</sub>	—	1.0	—	%	1Vpp standard staircase signal
Differential Phase	D <sub>P</sub>	—	1.0	—	deg	1Vpp standard staircase signal
S/N	SN	—	-75	—	dB	100% white video signal
Cross talk	CT	—	-60	-50	dB	fin=4.43MHz、1Vpp
MUTE attenuation	MT	—	-60	-50	dB	CIN : f = 4.43MHz ,1Vpp YIN,CVIN, Py/GIN, Pb/BIN, Pr/RIN : f=1MHz , 1Vpp
Group delay time 1	T1	—	40	80	ns	fin=100kHz
Group delay time 2	T2	—	22	50	ns	fin=100kHz
Group delay time deviation 1 (CIN, CVIN, YIN)	ΔT11	—	4	10	ns	fin=3.58MHz
	ΔT12	—	6	10	ns	fin=4.43MHz
	ΔT13	—	12	20	ns	fin=6MHz

Parameter	Symbol	Specifications			Unit	Conditions	
		Min.	TYP.	Max.			
Group delay time deviation 2 (Py/G IN、Pb/B IN、Pr/R IN)	$\Delta T_{21}$	—	1	10	ns	fin=2MHz	
	$\Delta T_{22}$	—	4	10	ns	fin=8MHz	
	$\Delta T_{23}$	—	10	20	ns	fin=12MHz	
Channel to channel Group delay time deviation 1	$\Delta Tch1$	—	1	10	ns	C $\leftrightarrow$ Y、fin=3.58MHz	
Channel to channel Group delay time deviation 2	$\Delta Tch2$	—	1	10	ns	Py/G $\leftrightarrow$ Pb/B $\leftrightarrow$ Pr/R、fin=2MHz	
S-DC Output voltage	L	$V_{SDCL}$	—	0.1	0.5	V	RL=10k $\Omega$ +100k $\Omega$ S1=L,S2=L
	M	$V_{SDCM}$	1.9	2.1	2.3	V	RL=10k $\Omega$ +100k $\Omega$ S1=L,S2=H S1=H,S2=H
	H	$V_{SDCH}$	4.3	4.6	—	V	RL=10k $\Omega$ +100k $\Omega$ S1=H,S2=L
S-DC output impedance	$Z_{S-DC}$	—	200	—	$\Omega$		
MUTE Switching voltage	$V_{THH}$	2.0	—	VCC	V	MUTE OFF	
	$V_{THL}$	GND	—	0.7	V	MUTE ON	
SEL (CV /MIX) Switching voltage	$V_{THH}$	2.0	—	VCC	V	CV MODE CVIN $\rightarrow$ CVOUT	
	$V_{THL}$	GND	—	0.7	V	MIX MODE CIN,YIN $\rightarrow$ CVOUT	
SEL (BIAS/CLAMP) Switching voltage	$V_{THH}$	2.0	—	VCC	V	BIAS MODE Py/G IN $\rightarrow$ Py/G OUT	
	$V_{THL}$	GND	—	0.7	V	CLAMP MODE Py/G IN $\rightarrow$ Py/G OUT	
S1/S2 Switching voltage	$V_{THH}$	2.0	—	VCC	V	High	
	$V_{THL}$	GND	—	0.7	V	Low	
Control pins input current	$I_{IH}$	—	—	155	$\mu A$	VH= 4.5V	
	$I_{IL}$	—	—	20	$\mu A$	VL = 0.4V	

○Outer dimensions

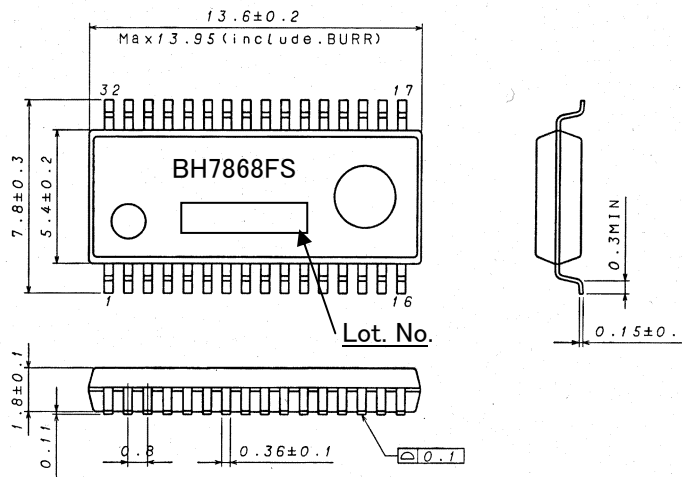

SSOP-A32 (Unit: mm)

○Block diagram

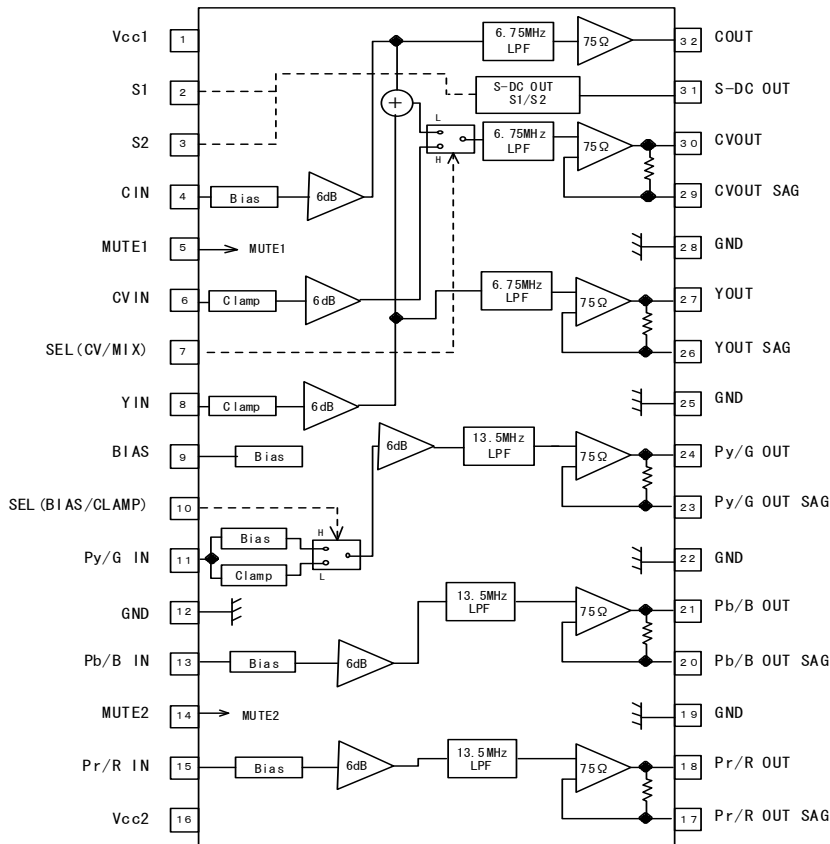

○Pin number and pin name

Pin No.	Pin name
1	Vcc1
2	S1
3	S2
4	CIN
5	MUTE1
6	CV IN
7	SEL(CV/MIX)
8	YIN
9	BIAS
10	SEL(BIAS/CLAMP)
11	Py/G IN
12	GND
13	Pb/B IN
14	MUTE2
15	Pr/R IN
16	Vcc2
17	Pr/R OUTSAG
18	Pr/R OUT
19	GND
20	Pb/B OUTSAG
21	Pb/B OUT
22	GND
23	Py/G OUTSAG
24	Py/G OUT
25	GND
26	YOUT SAG
27	YOUT
28	GND
29	CVOUT SAG
30	CVOUT
31	S-DCOUT
32	COUT

○Cautions on use

1) Absolute maximum ratings

If applied voltage, operating temperature range, or other absolute maximum ratings are exceeded, the LSI may be damaged. Do not apply voltages or temperatures that exceed the absolute maximum ratings. If you think of a case in which absolute maximum ratings are exceeded, enforce fuses or other physical safety measures and investigate how not to apply the conditions under which absolute maximum ratings are exceeded to the LSI.

2) GND potential

Make the GND pin voltage such that it is the lowest voltage even when operating below it. Actually confirm that the voltage of each pin does not become a lower voltage than the GND pin, including transient phenomena.

3) Thermal design

Perform thermal design in which there are adequate margins by taking into account the allowable power dissipation in actual states of use.

4) Shorts between pins and miss-installation

When mounting the LSI on a board, pay adequate attention to orientation and placement discrepancies of the LSI. If it is miss-installed and the power is turned on, the LSI may be damaged. It also may be damaged if it is shorted by a foreign substance coming between pins of the LSI or between a pin and a power supply or a pin and a GND.

5) Operation in strong magnetic fields

Adequately evaluate use in a strong magnetic field, since there is a possibility of malfunction.

## Notes

No copying or reproduction of this document, in part or in whole, is permitted without the consent of ROHM Co.,Ltd.

The content specified herein is subject to change for improvement without notice.

The content specified herein is for the purpose of introducing ROHM's products (hereinafter "Products"). If you wish to use any such Product, please be sure to refer to the specifications, which can be obtained from ROHM upon request.

Examples of application circuits, circuit constants and any other information contained herein illustrate the standard usage and operations of the Products. The peripheral conditions must be taken into account when designing circuits for mass production.

Great care was taken in ensuring the accuracy of the information specified in this document. However, should you incur any damage arising from any inaccuracy or misprint of such information, ROHM shall bear no responsibility for such damage.

The technical information specified herein is intended only to show the typical functions of and examples of application circuits for the Products. ROHM does not grant you, explicitly or implicitly, any license to use or exercise intellectual property or other rights held by ROHM and other parties. ROHM shall bear no responsibility whatsoever for any dispute arising from the use of such technical information.

The Products specified in this document are intended to be used with general-use electronic equipment or devices (such as audio visual equipment, office-automation equipment, communication devices, electronic appliances and amusement devices).

The Products specified in this document are not designed to be radiation tolerant.

While ROHM always makes efforts to enhance the quality and reliability of its Products, a Product may fail or malfunction for a variety of reasons.

Please be sure to implement in your equipment using the Products safety measures to guard against the possibility of physical injury, fire or any other damage caused in the event of the failure of any Product, such as derating, redundancy, fire control and fail-safe designs. ROHM shall bear no responsibility whatsoever for your use of any Product outside of the prescribed scope or not in accordance with the instruction manual.

The Products are not designed or manufactured to be used with any equipment, device or system which requires an extremely high level of reliability the failure or malfunction of which may result in a direct threat to human life or create a risk of human injury (such as a medical instrument, transportation equipment, aerospace machinery, nuclear-reactor controller, fuel-controller or other safety device). ROHM shall bear no responsibility in any way for use of any of the Products for the above special purposes. If a Product is intended to be used for any such special purpose, please contact a ROHM sales representative before purchasing.

If you intend to export or ship overseas any Product or technology specified herein that may be controlled under the Foreign Exchange and the Foreign Trade Law, you will be required to obtain a license or permit under the Law.



Thank you for your accessing to ROHM product informations.  
More detail product informations and catalogs are available, please contact us.

## ROHM Customer Support System

<http://www.rohm.com/contact/>

# Mouser Electronics

Authorized Distributor

Click to View Pricing, Inventory, Delivery & Lifecycle Information:

[ROHM Semiconductor:](#)

[BH7868FS-E2](#)