

AN5637

SECAM decoder IC

■ Overview

The AN5637 is a chroma signal processing circuit for use in SECAM system. It outputs the color difference signal.

■ Features

- Built-in bell filter, deemphasis circuit
- One point adjustment
- Small number of external components

■ Applications

- SECAM system TV

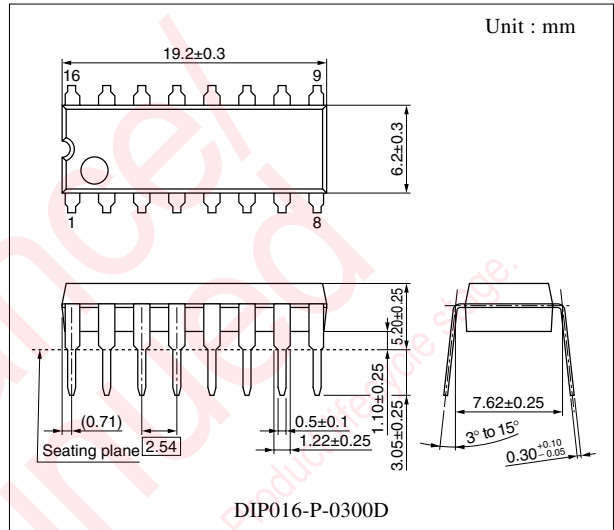

Note) The package of this product will be changed to lead-free type (DIP016-P-0300M). See the new package dimensions section later of this datasheet.

■ Block Diagram

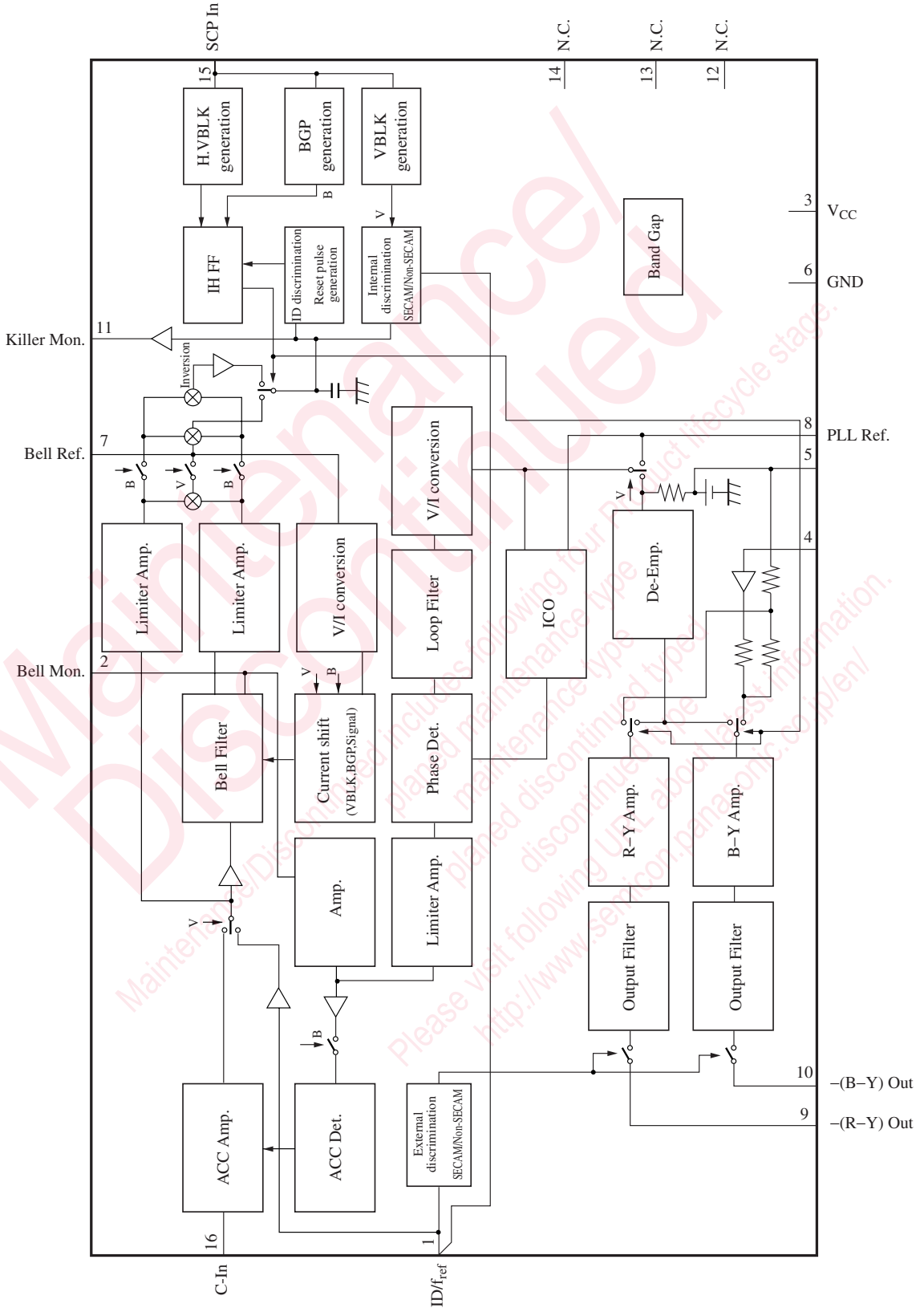

■ Pin Descriptions

Pin No.	Description	Pin No.	Description
1	Reference frequency signal/ Ident input pin	8	PLL filter automatic adjustment sample hold pin
2	Bell filter output monitor pin	9	– (R–Y) output pin
3	Power supply pin	10	– (B–Y) output pin
4	Black level adjustment voltage input pin	11	Killer voltage monitor pin
5	Black level adjustment reference voltage output pin	12	N.C.
		13	N.C.
6	Grounding pin	14	N.C.
7	Bell filter automatic adjustment sample hold pin	15	Sand castle pulse input pin
		16	SECAM signal input pin

■ Absolute Maximum Ratings

Parameter	Symbol	Rating	Unit
Supply voltage	V_{CC}	11.0	V
Supply current	I_{CC}	73	mA
Power dissipation *2	P_D	777	mW
Operating ambient temperature *1	T_{opr}	–20 to +70	°C
Storage temperature *1	T_{stg}	–55 to +150	°C

Note) *1 : $T_a = 25\text{ °C}$ except operating ambient temperature and storage temperature.

*2 : Power dissipation of the package at $T_a = 70\text{ °C}$.

■ Recommended Operating Range

Parameter	Symbol	Range	Unit
Supply voltage	V_{CC}	7.2 to 9.9	V

■ Electrical Characteristics at $V_{CC} = 9\text{ V}$, $T_a = 25\text{ °C}$

Parameter	Symbol	Conditions	Min	Typ	Max	Unit
Power supply						
Supply current	I_3	Current when $V_{CC} = 9\text{ V}$	30	40	50	mA
Pin voltage	V_5	Voltage when $V_{CC} = 9\text{ V}$	2.9	3.2	3.5	V

■ Electrical Characteristics at $V_{CC} = 9\text{ V}$, $T_a = 25\text{ °C}$ (continued)

Parameter	Symbol	Conditions	Min	Typ	Max	Unit
Input(Pin16)		Typical input : (Pin16) Color bar signal, (Pin15) Sand castle pulse, (Pin1) 4.43362 MHz sine wave 350 mV[p-p], V-BLK period				
Input dynamic range	V_{DR16}	Composite signal input amplitude range	—	1.0	1.5	V
Chroma signal input amplitude *1	$V_{ch.16}$	Chroma signal input amplitude range	—	—	300	mV[p-p]
Input impedance	Z_{16}	DC measurement	17	25	33	k Ω
Bell filter		Typical input : (Pin16) 4.0 MHz to 4.6 MHz sine wave 10 mV[p-p], (Pin15) Sand castle pulse, (Pin1) 4.43362 MHz sine wave 350 mV[p-p], V-BLK period				
Bell adjusting voltage	V_{ADB}	Sample hold pin voltage at bell filter automatic adjustment	2.8	3.9	5	V
Center frequency	f_{OB}	Center frequency of bell filter (Signal period)	4.202	4.262	4.322	MHz
Band width	B	Band width of bell filter (Signal period)	250	310	370	kHz
ACC		Typical input : (Pin16) Color bar signal (Composite) 1 V[p-p], (Pin15) Sand castle pulse, (Pin1) 4.43362 MHz sine wave 350 mV[p-p], V-BLK period				
ACC characteristics 1	ACC1	Output change amount when discrimination signal changes from 150 mV[p-p] to 300 mV[p-p]	-6	0	6	%
ACC characteristics 2	ACC2	Output change amount when discrimination signal changes from 150 mV[p-p] to 15 mV[p-p]	-6	0	6	%
Demodulator/Output		Typical input : (Pin16) Color bar signal (Composite) 1 V[p-p], (Pin15) Sand castle pulse, (Pin1) 4.43362 MHz sine wave 350 mV[p-p], V-BLK period				
PLL adjusting voltage	V_{ADV}	Sample hold pin voltage at PLL automatic adjustment	3.1	3.7	4.3	V
R-Y output amplitude	V_{RY}	Color bar (Composite) signal input (1 V[p-p])	0.85	1.00	1.15	V[p-p]
B-Y output amplitude	V_{BY}	Color bar (Composite) signal input (1 V[p-p])	1.07	1.27	1.47	V[p-p]
Detector output linearity	L_O	Color bar (Composite) signal input (1 V[p-p])	-6	0	6	%
R-Y/B-Y output ratio	(R-Y)(B-Y)	Amplitude ratio of V_{RY} and V_{BY}	1.12	1.27	1.42	Times
Black level adjusting voltage *2	V_{AD4}	Pin4 voltage when difference of B-Y black level becomes 0	1.45	2.1	2.75	V
Black level error (R-Y) *2	f_{BER}	Value referred to input frequency	—	—	10	kHz

Note) *1 : Refer to "Explanations of testing method 1"

*2 : Refer to "Explanations of testing method 2"

■ Electrical Characteristics at $V_{CC} = 9\text{ V}$, $T_a = 25\text{ °C}$ (continued)

Parameter	Symbol	Conditions	Min	Typ	Max	Unit
Demodulator/Output (continued)	Typical input : (Pin16) Color bar signal (Composite) 1 V[p-p], (Pin15) Sand castle pulse, (Pin1) 4.43362 MHz sine wave 350 mV[p-p], V-BLK period					
Blanking period output DC voltage	V_{BLK}	Stable sine wave is necessary in V period (4.4336 MHz)	2.2	2.7	3.2	V
SN ratio *3	S/N	Amplitude ratio when Deviation = 460 kHz/0 kHz (Pin10 measurement)	30	—	—	dB
Residual high frequency amplitude	V_{RH}	Harmonic content with 100 % white signal input (Pin10 measurement)	—	—	10	mV[p-p]
Output impedance (when SECAM) Pin9	Z_{OS9}	DC measurement, Pin1 = 5 V	260	460	660	Ω
Output impedance (when non SECAM) Pin9	Z_{ON9}	DC measurement, Pin1 = 1.5 V	1	—	—	M Ω
Output impedance (when SECAM) Pin10	Z_{OS10}	DC measurement, Pin1 = 5 V	260	460	660	Ω
Output impedance (when non SECAM) Pin10	Z_{ON10}	DC measurement, Pin1 = 1.5 V	1	—	—	M Ω
Sand castle pulse	Typical input : (Pin1) 4.43362 MHz sine wave 350 mV[p-p], V-BLK period					
Horizontal and vertical BLK level *4	V_{BL}	Measurement of slice level of H, V blanking pulse	0.5	1	1.5	V
Burst gate level *5	V_{BG}	Measurement of slice level of burst gate pulse	3.4	3.9	4.4	V
Reference signal/interface	Typical input : (Pin1) 4.43362 MHz sine wave 350 mV[p-p], V-BLK period					
Reference signal amplitude	V_{ref}	Amplitude range of sine wave (4.43362 MHz) of Pin1 input	0.20	—	0.50	V[p-p]
System SW discrimination level	V_{SS}	Voltage when Pin10 becomes open if Pin1 is 5 V to 1 V variable	2.5	3.0	3.5	V
IDENT	Typical input : (Pin16) Color bar signal (Chroma), (Pin15) Sand castle pulse, (Pin1) 4.43362 MHz sine wave 350 mV[p-p], V-BLK period					
Color On/Off hysteresis	H_C	Difference between color turn On or Off and Off to On level	0.5	2	6	dB
Killer sensitivity	K	Color turn Off level when discrimination signal changes 150 mV[p-p] to 0 mV[p-p]	—	—	-32	dB

Note) *3 : Refer to "Explanations of testing method 3"

*4 : Refer to "Explanations of testing method 4"

*5 : Refer to "Explanations of testing method 5"

■ Electrical Characteristics at $V_{CC} = 9\text{ V}$, $T_a = 25\text{ }^\circ\text{C}$ (continued)

• Design reference data

Note) The characteristic values below are theoretical values for designing and not guaranteed.

Parameter	Symbol	Conditions	Min	Typ	Max	Unit
Reference signal/interface						
Sink current	I_{SS}	Sink current of Pin1 when SECAM signal input	150	175	220	μA
Bell filter						
Center frequency power supply voltage dependency	$\Delta f_{OB}/\Delta V_{CC}$	Amount of center frequency fluctuation when $V_{CC} = 7.2\text{ V}$ to 9.9 V	—	0.23	—	kHz/V
Center frequency ambient temperature dependency	$\Delta f_{OB}/\Delta T$	Amount of center frequency fluctuation when $T_a = 30\text{ }^\circ\text{C}$ to $80\text{ }^\circ\text{C}$	—	0.25	—	$\text{kHz}/^\circ\text{C}$
Demodulator/Output						
Output signal bandwidth	B_S	Bandwidth of demodulator output signal (Pin9, 10)	—	1.3	—	MHz
Deemphasis pole-frequency	f_{PD}	Automatic adjustment period	—	85	—	kHz
Pole zero point frequency ratio	f_{PD}/f_{OD}	Automatic adjustment period	—	3	—	Times
R–Y output amplitude power supply voltage dependency	$\Delta V_{RY}/\Delta V_{CC}$	Fluctuation amount of R–Y output amplitude when $V_{CC} = 7.2\text{ V}$ to 9.9 V	—	1.5	—	%
R–Y output amplitude ambient temperature dependency	$\Delta V_{RY}/\Delta T$	Fluctuation amount of R–Y output amplitude when $T_a = -30\text{ }^\circ\text{C}$ to $+80\text{ }^\circ\text{C}$	—	0.36	—	$\text{mV}[\text{p-p}]/^\circ\text{C}$
B–Y output amplitude power supply voltage dependency	$\Delta V_{BY}/\Delta V_{CC}$	Fluctuation amount of B–Y output amplitude when $V_{CC} = 7.2\text{ V}$ to 9.9 V	—	2.0	—	%
B–Y output amplitude ambient temperature dependency	$\Delta V_{BY}/\Delta T$	Fluctuation amount of B–Y output amplitude when $T_a = -30\text{ }^\circ\text{C}$ to $+80\text{ }^\circ\text{C}$	—	0.55	—	$\text{mV}[\text{p-p}]/^\circ\text{C}$
Black level error (R–Y) power supply voltage dependency	$\Delta f_{BER}/\Delta V_{CC}$	Fluctuation amount of black level error (R–Y) when $V_{CC} = 7.2\text{ V}$ to 9.9 V	—	1	—	kHz/V
Black level error (R–Y) ambient temperature dependency	$\Delta f_{BER}/\Delta T$	Fluctuation amount of black level error (R–Y) when $T_a = -30\text{ }^\circ\text{C}$ to $+80\text{ }^\circ\text{C}$	—	50	—	$\text{Hz}/^\circ\text{C}$
Black level error (B–Y) power supply voltage dependency	$\Delta f_{BEB}/\Delta V_{CC}$	Fluctuation amount of black level error (B–Y) when $V_{CC} = 7.2\text{ V}$ to 9.9 V	—	2	—	kHz/V
Black level error (B–Y) ambient temperature dependency	$\Delta f_{BEB}/\Delta T$	Fluctuation amount of black level error (B–Y) when $T_a = -30\text{ }^\circ\text{C}$ to $+80\text{ }^\circ\text{C}$	—	90	—	$\text{Hz}/^\circ\text{C}$

■ Electrical Characteristics at $V_{CC} = 9\text{ V}$, $T_a = 25\text{ }^\circ\text{C}$ (continued)

• Explanations of testing method

1. Measurement of B–Y discrimination signal amplitude

2.

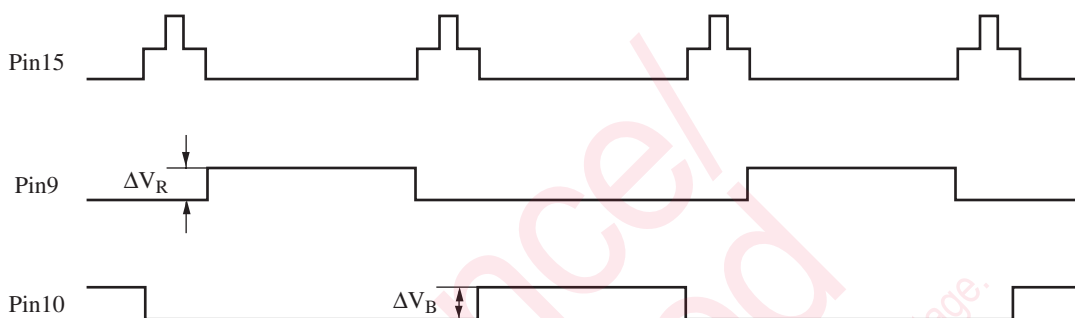

Input 100 % white signal and adjust the voltage of Pin4 so that ΔV_B becomes 0 mV. Let the adjusted voltage be V_{AD4} .

And let the value of ΔV_R based on input frequency at that time be f_{BER} , black level error (R–Y).

3. Calculate by using the value of Pin10 (B–Y) output amplitude V_{BY} when the color bar signal (Deviation = 460 kHz) is input to Pin16 and the value of Pin10 output V_{NOISE} when the color bar signal (Deviation = 0 Hz) is input.

$$S/N = 20 \log_{10} |V_{BY}/V_{NOISE}|$$

4. The horizontal and vertical blanking level V_{BL} is determined by the internal stabilizing power supply circuit.

5. The burst gate level V_{BG} is determined by dividing the IC built-in resistor between V_{CC} -GND.

$$V_{BG} = V_{CC} \times 3.8/9 \text{ (typ.)}$$

■ Terminal Equivalent Circuits

Pin No.	Equivalent circuit	Description	Voltage
1		<p>Reference frequency signal/ Ident input Pin :</p> <ul style="list-style-type: none"> • Input and output pin for interfacing with AN5192/95. • The circuit becomes non-SECAM mode if DC voltage of Pin1 becomes 3 V or less. • Current of 175 µA sinks into Pin1 in SECAM. 	<p>AC + DC</p> <p>DC 1.1 V or 4.4 V</p> <p>AC 350 mV[p-p] or 0</p>
2		<p>Bell filter output monitor pin</p>	<p>AC + DC</p> <p>DC 4.3 V</p> <p>AC 200 mV[p-p]</p>
3	—	Power supply pin	DC : 9 V
4		<p>Black level adjustment voltage input pin :</p> <ul style="list-style-type: none"> • Monitoring $-(B-Y)$ Out (Pin10), adjust Pin4 voltage so that pedestal step difference becomes 0. (using external volume) • Pin4 voltage is generated by resistor dividing Pin5 voltage so as not to be affected by V_{CC} and temperature fluctuation. 	<p>DC 1.45 V to 2.75 V</p>
5		<p>Black level adjustment reference voltage output pin</p>	<p>DC : 3.2V</p>

■ Terminal Equivalent Circuits (continued)

Pin No.	Equivalent circuit	Description	Voltage
6	—	Grounding pin	DC : 0 V
7		Bell filter automatic adjustment sample hold pin	DC 2.5 V to 5.0 V
8		PLL automatic adjustment sample hold pin	DC 3.6 V to 3.9 V
9 10		Pin9 ; -(R-Y) output pin Pin10; -(B-Y) output pin	AC + DC AC -(R-Y) -(B-Y) DC : 2.9 V

■ Terminal Equivalent Circuits (continued)

Pin No.	Equivalent circuit	Description	Voltage
11		Killer voltage monitor pin When SECAM more than 4 V When non-SECAM 3 V	DC 1.5 V to 5 V
12	—	N.C.	—
13	—	N.C.	—
14	—	N.C.	—
15		Sand castle pulse input pin	AC
16		SECAM signal input pin	AC 1.0 V [p-p]

■ Application Circuit Example

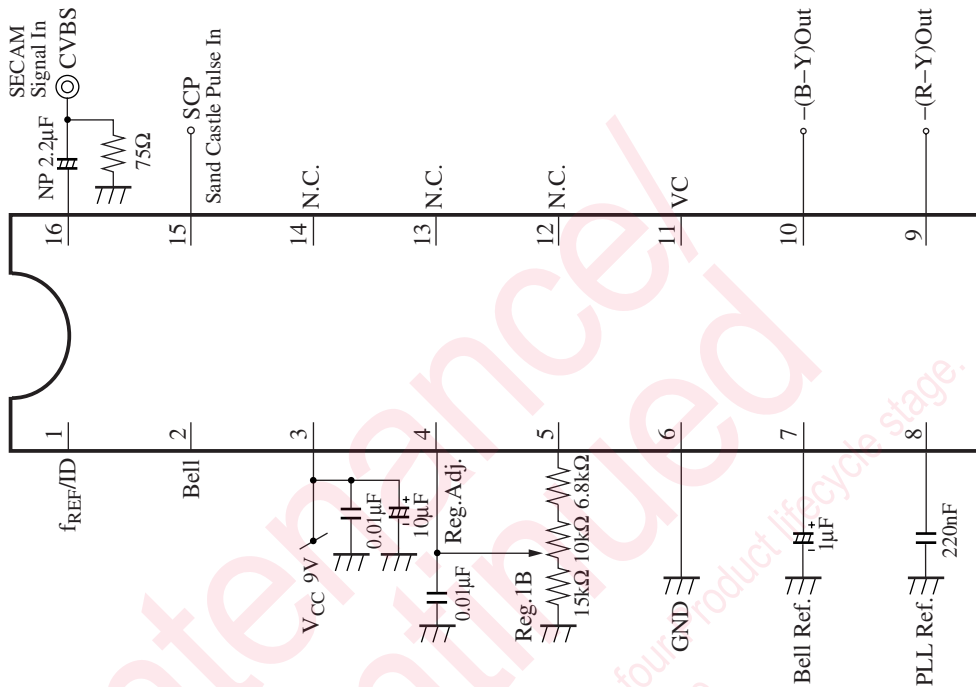

Note) The following signal is inputted to Pin1 from the AN5192/95.

• System discrimination

1. Pin1 is the input and output pin for the three pieces of information
 - (1) Reference frequency signal input pin (AC)
 - (2) System discrimination signal input pin (DC voltage)
 - (3) SECAM/Non-SECAM discrimination output pin (DC current)

AN5637 System discrimination	Pin1 input DC voltage	Pin1 sink current	Pin9, 10 output
SECAM	"H" (4.6 V)	175 µA	Color difference signal output
	"L" (1.3 V)	175 µA	Open
Non-SECAM	"H" (4.6 V)	0 µA	DC voltage output
	"L" (1.5 V)	0 µA	Open

2. Reference frequency signal

The reference frequency signal input for Pin1 is used for the following 4 signals ;

- (1) Bell filter automatic adjustment
- (2) PLL(VCO) automatic adjustment
- (3) Deemphasis automatic adjustment
- (4) Ident discrimination

Be sure to input the high precision PAL carrier signal (4.43362 MHz) only in the vertical retrace period.

■ New Package Dimensions (Unit: mm)

- DIP016-P-0300M (Lead-free package)

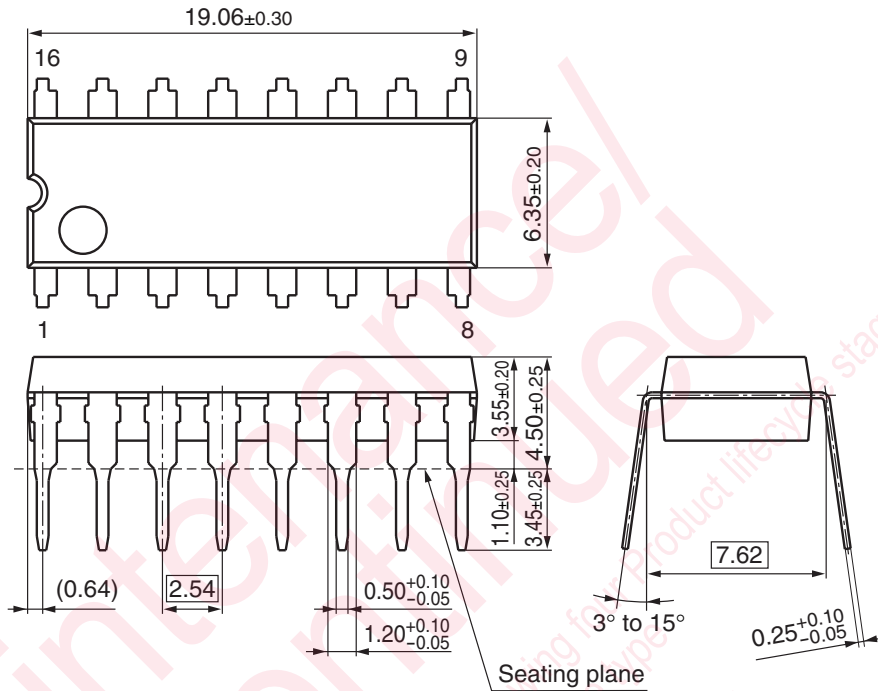

Request for your special attention and precautions in using the technical information and semiconductors described in this book

- (1) If any of the products or technical information described in this book is to be exported or provided to non-residents, the laws and regulations of the exporting country, especially, those with regard to security export control, must be observed.
- (2) The technical information described in this book is intended only to show the main characteristics and application circuit examples of the products, and no license is granted under any intellectual property right or other right owned by our company or any other company. Therefore, no responsibility is assumed by our company as to the infringement upon any such right owned by any other company which may arise as a result of the use of technical information described in this book.
- (3) The products described in this book are intended to be used for standard applications or general electronic equipment (such as office equipment, communications equipment, measuring instruments and household appliances).
Consult our sales staff in advance for information on the following applications:
 - Special applications (such as for airplanes, aerospace, automobiles, traffic control equipment, combustion equipment, life support systems and safety devices) in which exceptional quality and reliability are required, or if the failure or malfunction of the products may directly jeopardize life or harm the human body.
 - Any applications other than the standard applications intended.
- (4) The products and product specifications described in this book are subject to change without notice for modification and/or improvement. At the final stage of your design, purchasing, or use of the products, therefore, ask for the most up-to-date Product Standards in advance to make sure that the latest specifications satisfy your requirements.
- (5) When designing your equipment, comply with the range of absolute maximum rating and the guaranteed operating conditions (operating power supply voltage and operating environment etc.). Especially, please be careful not to exceed the range of absolute maximum rating on the transient state, such as power-on, power-off and mode-switching. Otherwise, we will not be liable for any defect which may arise later in your equipment.
 - Even when the products are used within the guaranteed values, take into the consideration of incidence of break down and failure mode, possible to occur to semiconductor products. Measures on the systems such as redundant design, arresting the spread of fire or preventing glitch are recommended in order to prevent physical injury, fire, social damages, for example, by using the products.
- (6) Comply with the instructions for use in order to prevent breakdown and characteristics change due to external factors (ESD, EOS, thermal stress and mechanical stress) at the time of handling, mounting or at customer's process. When using products for which damp-proof packing is required, satisfy the conditions, such as shelf life and the elapsed time since first opening the packages.
- (7) This book may be not reprinted or reproduced whether wholly or partially, without the prior written permission of Matsushita Electric Industrial Co., Ltd.