

# 5-channel BTL Driver for DVD player

## AM5668S

The AM5668S is a five-channel BTL driver IC for driving the motors and actuators such as used in DVD player and consists of two independent precision voltage comparators. It supports a variety of applications.

### ● Applications

BTL driver for CD, CD-ROM and DVD.

### ● Features

- 1) Two channels are voltage-type BTL drivers for actuators of tracking and focus. Two channels are voltage-type BTL driver for sled and spindle motors. It is also built-in one channel bi-direction DC motor driver for tray.
- 2) Wide dynamic range [9.0V (*typ.*) when  $V_{cc1}=V_{cc2}=12V$ , at  $R_L=20\Omega$  load].
- 3) Separating power of  $V_{cc1}$  and  $V_{cc2}$  is to improve power efficiency by a low supply voltage for tracking, focus, and spindle.
- 4) Level shift circuit built-in.
- 5) Thermal shut down circuit built-in.
- 6) Mute mode built-in.
- 7) **Dual actuator drivers:**  
A general purpose input OP provides differential input for signal addition. The output structure is two power OPAMPS in bridge configuration.
- 8) **Sled motor driver:**  
A general purpose input OP provides differential input for signal addition. The output structure is one power OPAMP in bridge configuration.
- 9) **Spindle driver:**  
Single input linear BTL driver. The output structure are two power OPAMPS in bridge configuration.
- 10) **Tray in-out driver:**  
The DC motor driver supports forward/reverse control for tray motor.

● **Absolute maximum ratings (Ta=25°C)**

Parameter	Symbol	Limits	Unit
Supply voltage	Vcc1 Vcc2	13.5	V
Power dissipation	P <sub>d</sub>	*1.7	W
Operate Temp range	T <sub>opr</sub>	-35 ~ +85	°C
Storage Temp range	T <sub>stg</sub>	**-.55 ~ +150	°C

\*When mounted on a 70mm × 70mm × 1.6mm glass epoxy board.

\*Reduced by 13.6mW for each increase in T<sub>a</sub> of 1°C over 25°C.

\*\*Should not exceed Pd or ASO and T<sub>j</sub>=150 °C values

● **Guaranteed operating conditions (Ta=25°C)**

Parameter	Symbol	Limits	Unit
Power supply voltage	Vcc1	4.3 ~ 13.2	V
	Vcc2	4.3 ~ Vcc1	V

● **Block diagram**

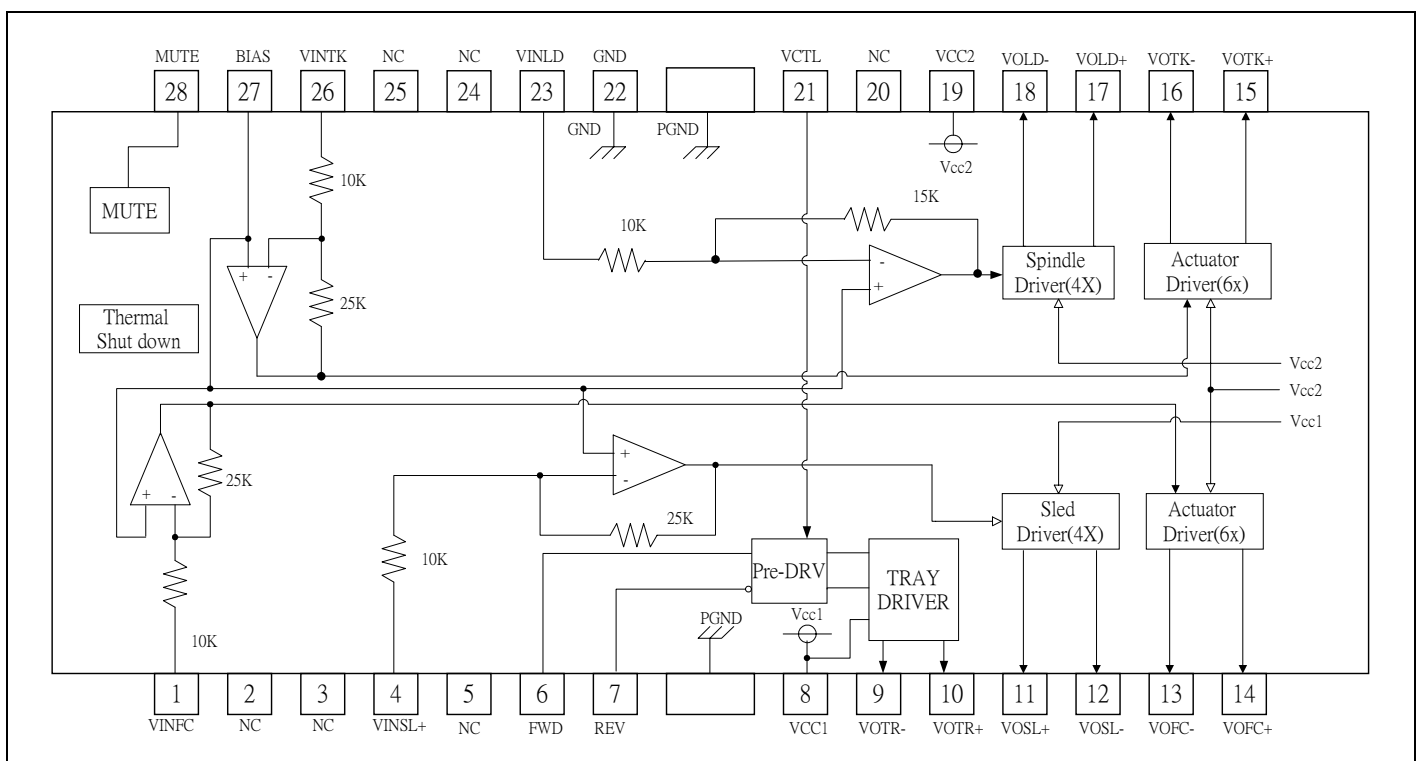

## ● Electrical characteristics

( Unless otherwise specified  $T_a=25^{\circ}\text{C}$ ,  $V_{cc1}=12\text{V}$ ,  $V_{cc2}=5\text{V}$ ,  $\text{BIAS}=2.5\text{V}$ ,  $R_L=8\Omega/10\Omega/20\Omega/45\Omega$ )

Parameter	Symbol	Limit			Unit	Conditions	P.S
		Min	Typ	Max			
Quiescent current	$I_{cc}$	-	30	-	mA		
Voltage for mute ON	$V_{ston}$	0	-	0.5	V		
Voltage for mute OFF	$V_{stoffs}$	2.0	-	5	V		
<b>&lt;Actuator drivers&gt;</b>							
Output offset voltage	$V_{oo}$	-	-	$\pm 50$	mV		
Maximum output voltage	$V_{om}$	3.6	4.0	-	V	@10 $\Omega$ Load	
Voltage gain	$G_v$	-	23.5	-	dB	$V_{IN}=\text{BIAS}+0.2\text{Vpp ac @1KHz}$	
<b>&lt;Sled motor driver&gt;</b>							
Output offset voltage	$V_{oofsl}$	-	-	$\pm 100$	mV		
Maximum output voltage	$V_{omsl}$	7.5	9.0	-	V	@20 $\Omega$ Load	
Closed loop voltage gain	$G_{vsl}$	18	20	22	dB	$V_{IN}=\text{BIAS}+0.2\text{Vpp ac @1KHz}$	
<b>&lt;Spindle motor driver&gt;</b>							
Output offset voltage	$V_{oofld}$	-	-	$\pm 50$	mV		
Maximum output voltage	$V_{omax}$	-	3.5	-	V	@8 $\Omega$ Load	
Voltage gain	$G_{vld}$	13.3	15.5	17.5	dB	$V_{IN}=\text{BIAS}+0.2\text{Vpp ac @1KHz}$	
Gain error by polarity	$\Delta G_{vld}$	0	1	2	dB	$V_{IN}=\text{BIAS}+0.2\text{Vpp ac @1KHz}$	
<b>&lt;Tray motor driver&gt;</b>							
Output saturation voltage 1	$V_{SAT1}$	0.7	1.1	1.5	V	Upper + Lower saturation, $I_L=200\text{mA}$	
Output saturation voltage between F&R	$\Delta V_{SAT1}$	-	-	0.1	V	Output saturation voltage 1 between FWD and REV	
Output saturation voltage 2	$V_{SAT2}$	1.0	1.55	2.2	V	Upper + Lower saturation, $I_L=500\text{mA}$	
Output adjustable gain on "H" side voltage	$V_{VtrH}$	7.4	9.2	11	dB	$V_{CTL}=2\text{V}$	
<b>&lt;Tray motor driver input logic&gt;</b>							
High level input voltage	$V_{IH}$	1.5	-	$V_{cc}$	V		
Low level input voltage	$V_{IL}$	-0.3	-	0.5	V		
High level input current	$I_{IH}$	-	180	270	$\mu\text{A}$	$V_{FWD}=V_{REV}=5\text{V}$	

\*This device is not designed for protection against radioactive rays.

● Pin configuration

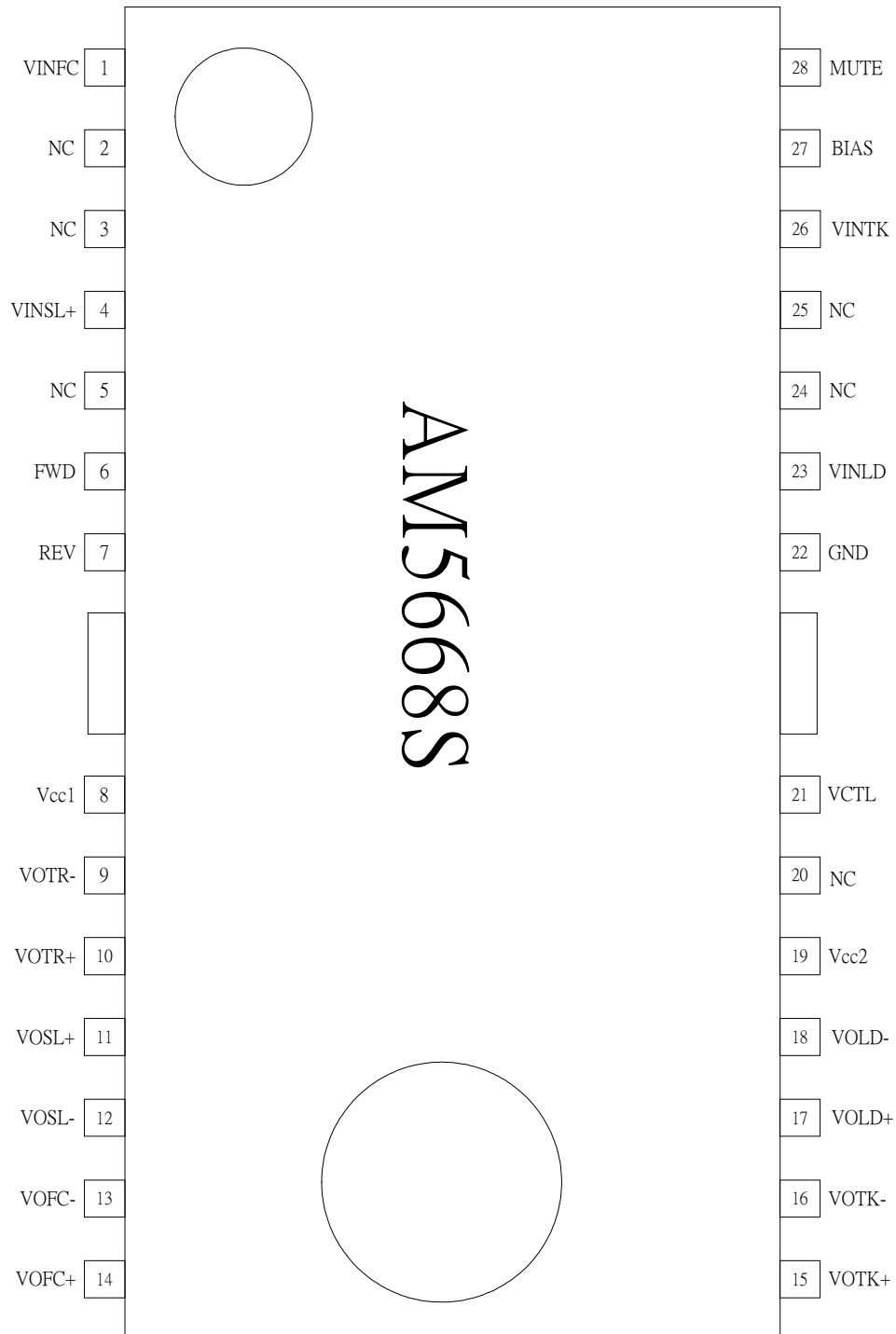

● **Pin description**

PIN No	Pin Name	Function
1	VINFC	Input for focus driver
2	NC	No connection
3	NC	No connection
4	VINSL+	Input for the sled driver
5	NC	No connection
6	FWD	Tray driver forward input
7	REV	Tray driver reverse input
8	Vcc1	Vcc for pre-drive block and power block of sled and tray
9	VOTR-	Tray driver output (-)
10	VOTR+	Tray driver output (+)
11	VOSL+	Sled driver output (+)
12	VOSL-	Sled driver output (-)
13	VOFC-	Focus driver output (-)
14	VOFC+	Focus driver output (+)
15	VOTK+	Tracking driver output (+)
16	VOTK-	Tracking driver output (-)
17	VOLD+	Spindle driver output (+)
18	VOLD-	Spindle driver output (-)
19	Vcc2	Vcc for power block of spindle, tracking and focus
20	NC	No connection
21	VCTL	Speed control input of tray driver
22	GND	Ground
23	VINLD	Input for spindle driver
24	NC	No connection
25	NC	No connection
26	VINTK	Input for tracking driver
27	BIAS	Input for reference voltage
28	MUTE	Input for mute control

Notes) Symbol of + and – (output of drivers) means polarity to input pin.  
(For example, if voltage of pin1 is high, pin14 is high.)

● **Power dissipation curve :**

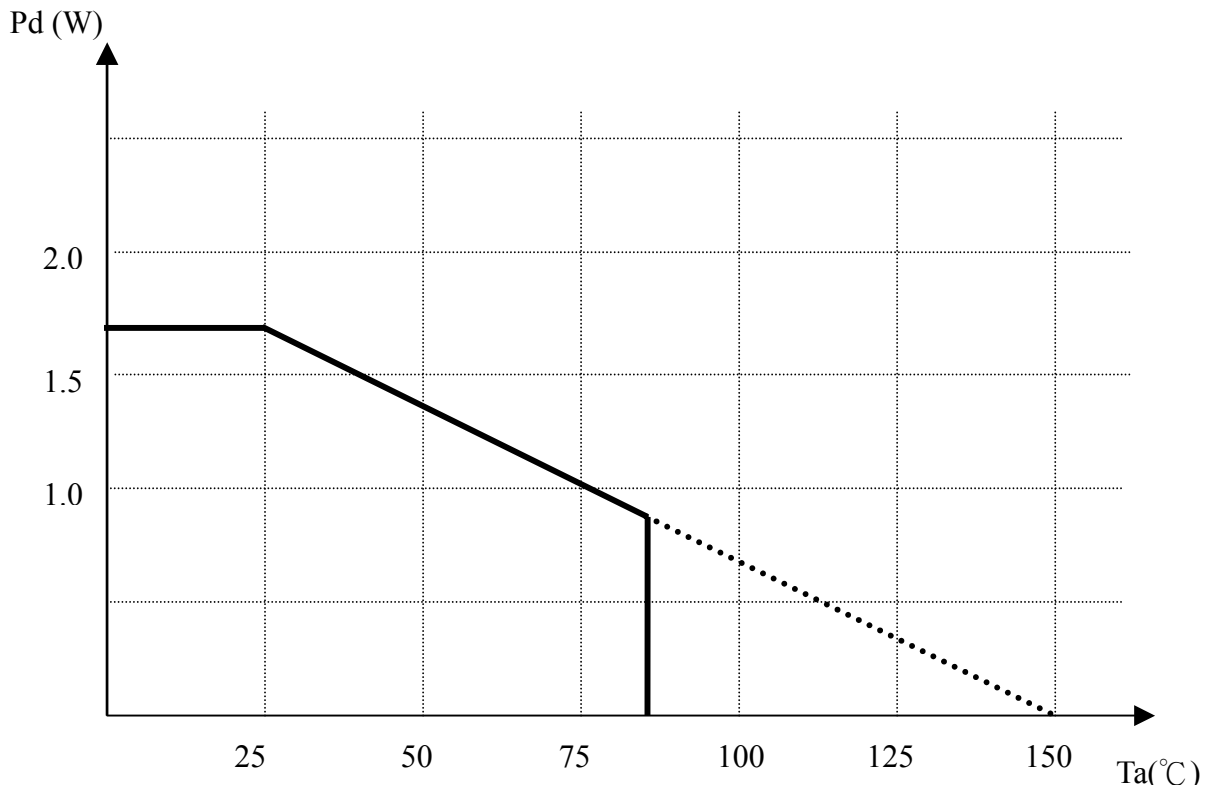

\*70mm × 70mm × 1.6mm glass epoxy board.

\*Derating is done at 13.6mW/°C for operating above  $T_a=25^\circ\text{C}$

● **Operation notes**

- 1) The built-in thermal shutdown circuit mutes the output current when the chip temperature reaches 175°C (typ.). The hysteresis is set to 25°C (typ.), so the circuit will start up again when the chip temperature falling to 150°C (typ.).
- 2) In case mute pin voltage is under 0.5V or NC, output current is muted (except for tray motor driver). Mute pin voltage should be more than 2.0V for normal application.
- 3) Bias pin (pin 27) should be pulled up to more than 1.2V. In case the bias pin voltage is pulled down below 0.9V (typ.), the output current is muted.
- 4) Insert the bypass capacitor (~ 0.1uF ) between Vcc pin and GND pin as close as possible.
- 5) Heat dissipation fins are attached to the GND on the inside of the package. Make sure to connect them to the external GND.

6) Tray driver logic input:

FWD (pin6)	REV (pin7)	VOTR+ (pin10)	VOTR- (pin9)	Function
L	L	OPEN	OPEN	Open mode
L	H	L	H	Reverse mode
H	L	H	L	Forward mode
H	H	L	L	Brake mode

Input circuit of pin6 and pin7 is designed to avoid simultaneous activation of upper and lower output tr. ; however, in order to improve reliability, apply motor forward/reverse input once through open mode.

We recommend time period for open longer than 10msec.

“H” side Output voltage on output voltage (VOL+, VOL-) varies depending on output control terminal for tray (pin21). “H” side output voltage is set three times (9.2dB Typ.) VTCL(pin21). And, “L” side output voltage is equal to output saturation voltage.

● Application circuit

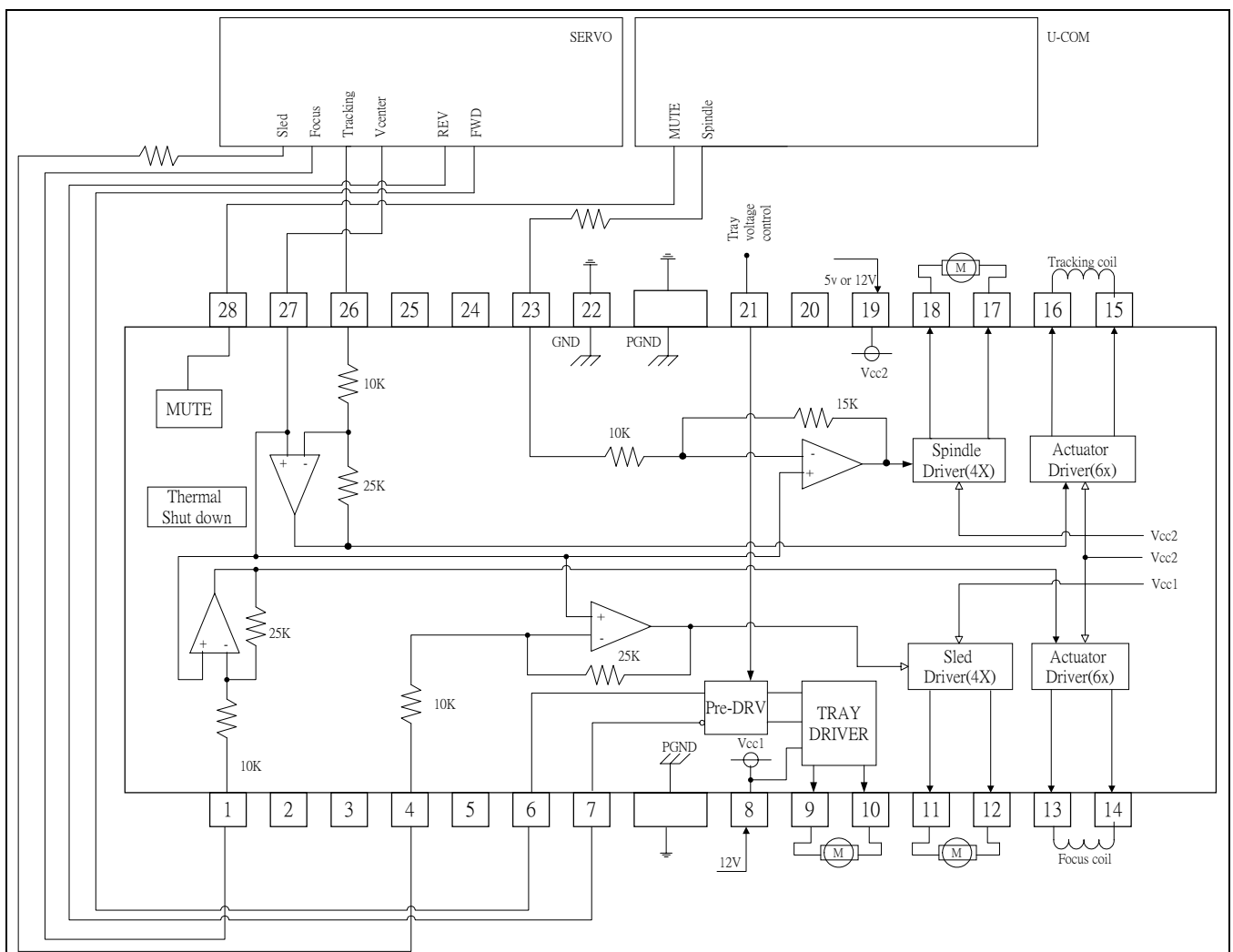

## ● Testing circuit

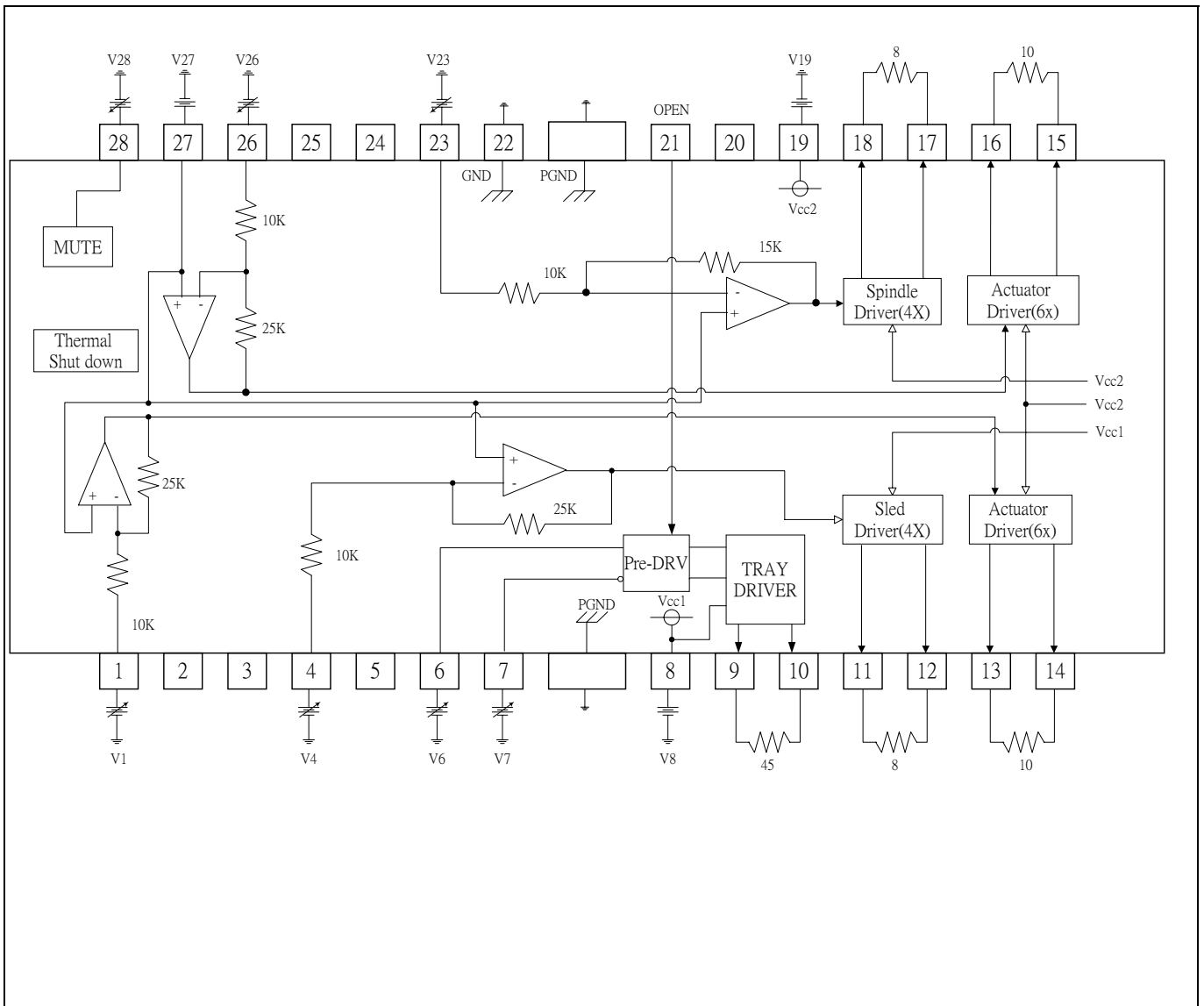



## ● Packaging outline

### HSOP28

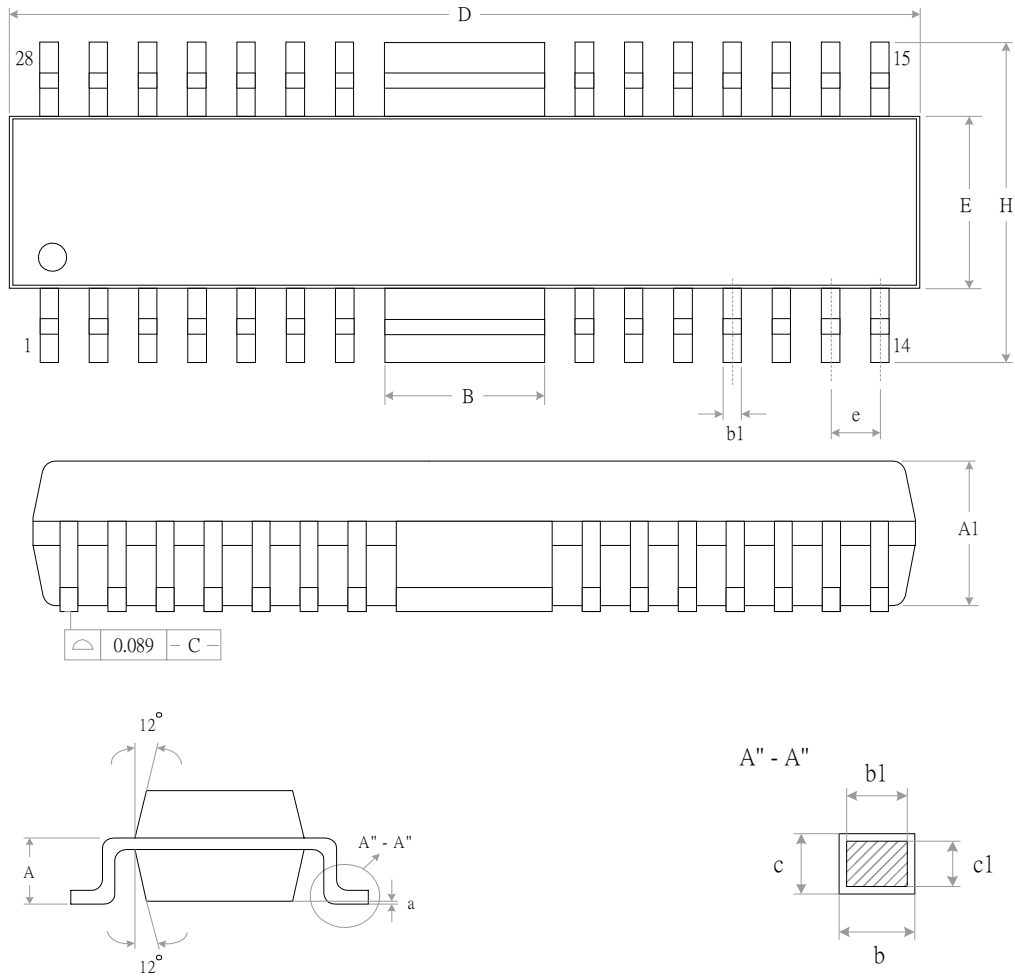

SYMBOL	MILLIMETERS		INCHES	
	Min.	Max.	Min.	Max.
A	-	2.31	-	0.091
A1	-	2.20	-	0.087
a	0.05	0.20	0.002	0.008
B	5.05	5.25	0.199	0.207
b	0.30	0.45	0.012	0.018
b1	0.30	0.40	0.012	0.016
c	0.23	0.30	0.009	0.012
c1	0.23	0.28	0.009	0.011
D	18.41	18.67	0.725	0.735
E	7.49	7.75	0.295	0.305
e	0.80 BSC		0.031 BSC	
H	9.62	10.02	0.379	0.394

## ● Marking Identification

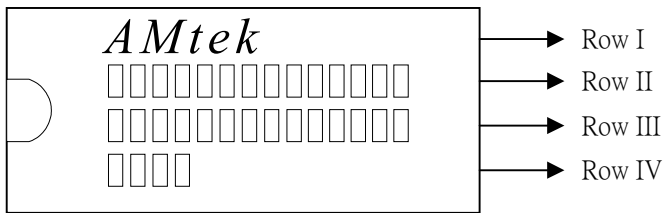

Row I

AMtek

Row II

Part number

Row III

Lot number

Row IV

Production week

